

powerbass®

X T R E M E



XL-400.1D
XL-600.1D

XL POWERSPORT CLASS D MONO AMPLIFIER

Owners Manual

Please read through this manual to familiarize yourself with your new amplifier. Should your PowerBass Xtreme mobile amplifier ever require service, you will need to have the original dated receipt.



AMPLIFIERS

Thank you and Congratulations

Thank you for your decision to purchase a PowerBass USA Xtreme mobile amplifier! Our new mini amplifiers are the result of extensive engineering, testing, and bullet proof construction. Their versatility enables compatibility with optional signal and audio processors. These high quality MOSFET amplifiers may be configured to allow maximum flexibility in designing different types of speaker systems.



COMPACT CLASS D AMPLIFIERS

Unlike most Full Range amplifiers, these models are designed specifically for low frequencies and are intended only to power subwoofers. It is important that you closely follow the wiring instructions contained in this Owners Manual so that you get the most from your PowerBass Xtreme Class D Mono mobile amplifier.

Δ Caution Δ

High powered audio systems in a vehicle are capable of generating higher than "Live Concert" levels of sound pressure. Continued exposure to excessively high volume sound levels could cause hearing loss or damage. Also, operation of a motor vehicle while listening to audio equipment at high volume levels may impair your ability to hear external sounds such as horns, warning signals, or emergency vehicles—thus creating a potential traffic hazard. In the interest of safety, PowerBass USA highly recommends listening at lower volume levels when driving.

TECHNICAL FEATURES

- Class D Mono Amplifier
- International Rectifier® Chip Set
- Conformal Coated PC Board to Resist Moisture, Dust and Extreme Heat
- AUX Input Accepts XL-BTR1, XL-BTRS, MP3, iPod® or Portable Source Device
- Wrap-around Aluminum Heatsink Shell
- Ultra Low Current Draw
- High Damping Control Circuit
- High Efficiency SMD Circuit Technology
- Double Sided Copper Plated PCB
- Digital Sound Optimization Circuitry
- Quiet Switching
- High Current Voltage Ripple Rejection Circuitry
- Virtual Silence Turn On/Off Mute Circuit
- Subsonic Filter (variable 10Hz-50Hz)
- Wired Remote Level Control
- Bass EQ
- Variable LPF
- Low Level RCA and High Level Speaker Inputs

**iPod® is a registered trademark of Apple*

INSTALLATION EXPERIENCE

Installation of PowerBass mobile amplifiers requires detailed knowledge of electronics wiring and proper speaker impedance. We strongly recommend installation by an authorized PowerBass dealer. This Owners Manual only provides general installation and operation instructions. If you have any reservations about your installation skills, please contact your local PowerBass dealer for assistance.

IMPORTANT : This amplifier is designed for operation in vehicles with 12-volt Negative ground electrical systems only.

PREPARING FOR INSTALLATION

NOTE: The tools listed below may be required for basic installation

- An electric drill with bits
- Philips head and standard screwdrivers
- Wire strippers
- Crimping tool
- VOM (electronic volt ohm meter)
- Heat shrink tubing and heat gun
- Soldering iron
- Electronic (Rosen not Acid Core) Solder

International
IR Rectifier
THE POWER MANAGEMENT LEADER

IR® is a registered trademark of International Rectifier Corporation.

INSTALLATION PRECAUTIONS

NOTE: Proceed only if you are a qualified installer, otherwise; see your Authorized PowerBass Dealer to professionally install this amplifier. Always wear protective eyewear when using tools.

- Turn off all stereo and other electrical devices before you begin.
- Disconnect the negative (-) lead from your vehicles battery.
- Locate all fuel lines, brake lines, oil lines, and electrical cables when planning the install.
- Make sure there is at least 2-inches (5 cm) around the air vents on the amplifier.
- When connecting ground points, make sure all paint is carefully scrapped away from the auto body and contact is made with bare metal.
- Use a utility knife to trim away fabric from hole locations before drilling or cutting.
- When running power cables through sheet metal, be sure to use grommets to properly insulate the metal edges from the wire insulation.
- If possible, use tubing through grommets.

WARNING: Check your vehicle's owner's manual before disconnecting the battery. Disconnecting the battery on some vehicles may require an anti-theft code when reconnecting the battery and require the on-board computer to be reset at the dealership. Check with your local dealer if you are uncertain.

MOUNTING THE AMPLIFIER

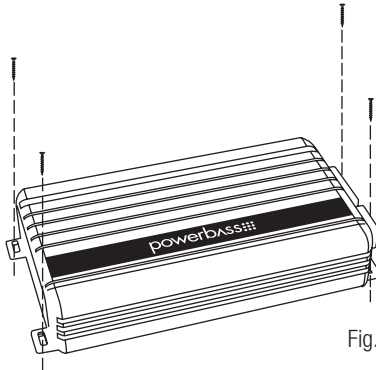

Fig.1 Mounting the Amplifier

Due to the high power output of the PowerBass Xtreme Class D amplifiers, considerable heat may be produced when the unit is in operation. For this reason the amplifier should be mounted in a location which will allow air to circulate freely. A clearance of at least 2-inches (5 cm) to all sides of the amplifier is necessary not only for proper cooling, but also for gaining access to the inputs and other variable controls. Be sure that the power and signal cable connections can enter and leave the amplifier in a straight line to avoid the risk of kinked wires causing malfunction.

CAUTION: Not water or mud proof. Cannot be submerged or it will void the warranty!

MOUNTING LOCATION

The XL Series amplifiers have a conformal coating applied to the PC board. This coating makes them resistant to water and dust—however they are not waterproof. Therefore, care should still be taken to protect the amplifier from water and find a mounting location that is not likely to get wet. Take care not to mount in a vehicle/vessel where it can cause interference with the factory installed electronic devices.

The unique wrap around outer shell (heatsink) allows the XL Series amplifiers to be mounted in spaces with minimal air flow. It is important that whatever location is selected the amplifier must be mounted securely in a manner keeps the unit intact even during rough jolts that can occur to the vehicle/vessel.

You may use the amplifier as a template and mark the four screw locations with a felt tip pen. Set the amplifier aside before drilling. Use caution to make sure there are no objects behind the installation surface that may become damaged during drilling.

If mounting under a seat, make sure there is at least 1-inch (2.5 cm) of space above the amplifier's heatsink to permit proper cooling.

The best places to mount your amplifier are: The floor of the trunk, under a seat, or on the back of the rear seat. For alternate installation locations, please consult your authorized PowerBass Dealer.

NOTE: Do not use a drill with driver bit to mount the amplifier. Excessive force could cause the plastic mounting feet to crack.

*** WARNING ***

- Do not install in a place where it could injure the driver or passengers if the vehicle stops suddenly.
- Try to avoid mounting the amplifier on a subwoofer enclosure, as extended exposure to vibration may cause malfunction of the amplifier.
- Don't mount the amplifier so that the wire connections are unprotected or are subject to pinching or damage from nearby objects.
- The DC power wire must be fused at the battery positive (+) terminal connection. Before making or breaking power connections at the amplifier power terminals, disconnect the DC power wire at the battery end.
- The battery of the car audio system must be disconnected until the entire wiring and installation is completed.

CONTROL PANEL LAYOUT

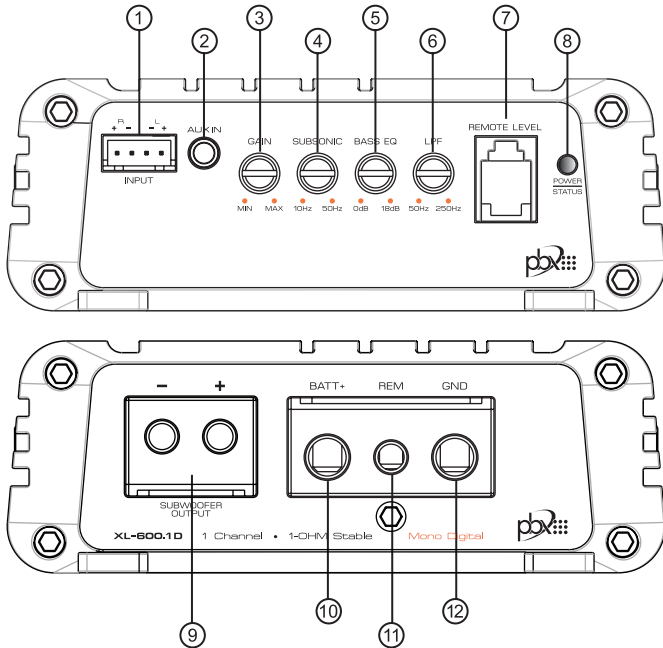

Fig.2 Panel Layout

NOTE: Panel Layout and Controls may differ by model.

1. HIGH/LOW INPUT

Use this Low Level 4-pin Molex style input is where the wiring harness plugs in for the Low Level input that connects to source units with RCA line level outputs. A source unit with a minimum input of 250mV is required for proper operation. However, this input can accept levels up to 10Vrms.

2. AUX Input Jack

This 1/8-inch (3.5mm) mini jack can be used to accept an MP3, iPod or smartphone as the source unit from that device's headphone (3.5mm) output.

3. GAIN Control

This control is used to match the input sensitivity of the amplifier to the particular source unit that you are using up to 10 volts.

4. SUBSONIC Control

This control is continuously adjustable from 10Hz through 50Hz at 12dB per octave to provide an extra level of speaker protection from bass robbing power at unheard frequencies.

5. BASS EQ Control

This equalization circuit is used to enhance the low frequency response of the vehicle's interior. With up to 18dB of boost centered at 45Hz, the BASS EQ can be adjusted to meet your own personal taste.

6. LPF (Low Pass Filter) Control

This filter controls low pass of frequencies and is adjustable from 50Hz through 250Hz to eliminate unwanted high frequencies.

7. REMOTE LEVEL

This is the connector port for the Remote Level Control. Now the amplifiers secondary gain circuit can be adjusted from the driver's seat.

8. POWER/STATUS Indicator

This clear LED lights Blue when the power is on—or turns Red constantly when the built-in protection circuitry is activated. Red indicates a problem with the system in relation to the amplifier (See Troubleshooting Tips).

9. SUBWOOFER OUTPUT

This terminal is the speaker output. Be sure to observe the correct speaker polarity and follow the speaker wiring diagrams found elsewhere in this owners manual.

10. BATT+ (Power Input Connection)

This terminal is the main power input for the amplifier and must be connected directly to the positive (+) terminal of the car battery. The solderless terminal block is designed to accommodate up to 8-gauge power wire.

11. REM (Remote Input Connection)

All PowerBass Xtreme amplifiers can be turned on by applying 12 volts to this terminal. This can be found on the rear of the source unit in the form of a remote output. If this is not available you can wire to the ACC position on the key. An 18 gauge wire is sufficient to run the REMOTE.

12. GND (Ground Input Connection)

A good quality ground is required for your PowerBass Xtreme amplifier to operate at peak performance. A short length of cable the same gauge as your power cable should be used to attach the ground terminal directly to the chassis of the vehicle. Make sure that all of the paint is sanded or scraped away to ensure a quality ground connection.

NOTE: If installing in a boat, UTV or motorcycle make sure your ground wire is connected to the negative (-) terminal of the battery.

FUSE-IMPORTANT

Due to the limited space on the XL amplifier chassis they do NOT come with internal fusing! Instead we have included an in-line fuse holder that can be connected directly to the BATT+ input on the amplifier. Please note the proper ampere fuse for each model are listed below. Never replace a fuse with a higher rating than what is listed.

XL-400.1D 40A

XL-600.1D 60A

CONNECTIONS TO AMPLIFIER FOR BATT+, GND, REM AND SPEAKERS

Your PowerBass Xtreme amplifier features specially tooled solderless terminals for Power (BATT+), Ground, Remote, and Speaker connections. For maximum transfer of Voltage and Signal the bare wire needs to be inserted as far as possible into the terminal before tightening the set screw. For Power (BATT+) and Ground connections it is highly recommended that the bare ends of the wires are tinned with solder before inserting them into the terminal. Hand tighten the set screw and make sure the connection is secure to prevent possible arcing due to loose screws.

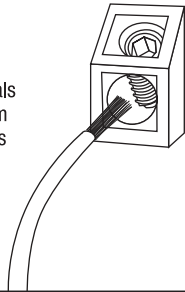

NOTE: It is highly recommended that an Allen wrench is used to tighten the set screws in the terminal blocks by hand and NOT a power drill. This will prevent stripping or other possible damage to the amplifier.

POWER WIRING AND SIGNAL CONNECTIONS

*** WARNING ***

Disconnect the negative (-) battery terminal before you start any wiring work! The battery of your car audio system must be disconnected until the entire wiring installation is completed.

Your PowerBass Xtreme Class D amp will draw large levels of current, so use the largest gauge power/ground cable as possible. Using too small of power cable can result in unnecessary over-heating of the amplifier, distortion at high volume levels and might even cause the thermal protection circuitry to shut-off the amplifier. Remember, bigger wire is better!

- Use rubber grommets when running cables through any metal or sharp plastic, to prevent accidental shorting or shearing. Make sure the cables do not interfere with normal operation of the vehicle.
- The audio signal cables (RCA interconnects) should be kept far away from any potential sources of electrical interference such as electronic vehicle management systems (relays, engine computers wiring harnesses, fuel pumps etc.)

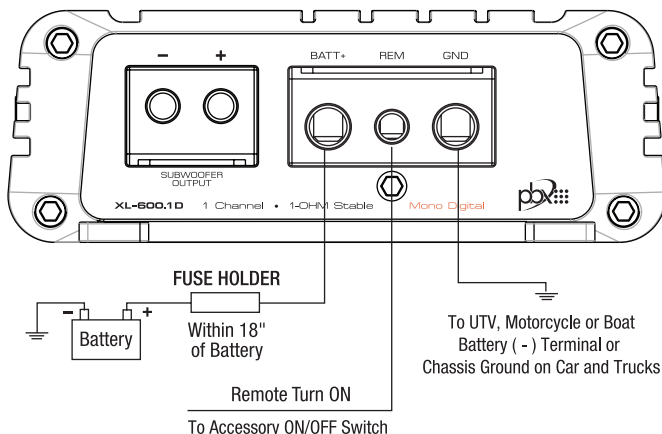

Fig.3 Power Input Connection

This amplifier is designed to work within a 9-16 volt DC range. Before any wires are connected, the vehicles electrical system should be checked for correct voltage supply with the help of a voltmeter.

First, check the voltage at the battery with the ignition in the OFF position. The voltmeter should read no less than 12V. If your vehicles electrical system is not up to these specifications, we recommend having it checked by an auto electrician before any further installation. Once the vehicle is checked, make certain the correct cable gauge is used. We recommend using as large a gauge cable as possible, use the Power Cable Selection Chart to calculate the correct power wire size for your application.

POWER WIRING

BATT+ (Power)

This amplifier should be wired directly to the vehicle battery using the appropriate size cable. Start at the vehicle battery and run the power cable through to the amplifier. Avoid running the power cable over engine components and near heater cores. **The use of an inline fuse or circuit breaker is a must;** this will prevent the risk of a potential fire caused by a short in your power cable. Connect the fuse holder or circuit breaker as close to the battery positive (+) terminal as possible (no farther than 18" from that battery). This fuse or circuit breaker should be no greater than the sum of the fuses found on the chassis of your amplifier (also see specifications chart). You may now connect the cable to the battery, but remember to leave the fuse out or circuit breaker "off" until all other cable connections are made.

GND (Ground)

When grounding your amplifier, locate a metal area close to the amplifier that is good source of ground (preferable the floor pan). Once again, investigate the area you wish to use for electrical wires, vacuum lines, and brake or fuel lines. Use either a wire brush or sandpaper to eliminate unwanted paint for better contact of the ground.

Secure the ground cable to the body using a bolt, star washer and nut. Spread silicon over the screw and bare metal to prevent rust and possible water leaks.

NOTE: If installing in a boat, UTV or motorcycle make sure your ground wire is connected to the negative (-) terminal of the battery. See Fig. 5

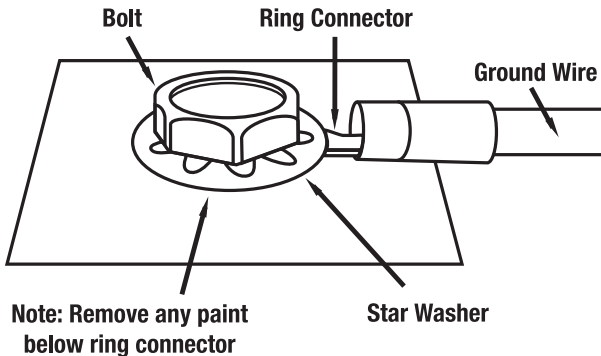

Fig.4 Proper Chassis Ground Connection For Cars And Trucks

Now it's time to connect the power and ground cables to the amplifier. Cut both cables to length. Strip off 1/2 inch (12mm) of the insulation so that the bare wire fits all the way in the terminal block on the side panel of the amplifier, seating it firmly so no bare wire is exposed. Use an Allen wrench to loosen the BATT+ and the GND connections on the amplifier. Insert the ground first, and then the +12V and please make sure that you place them into the correctly marked terminals. Then tighten the screws down securely by hand.

Proper Ground Connection For UTVs, Motorcycles or Boats

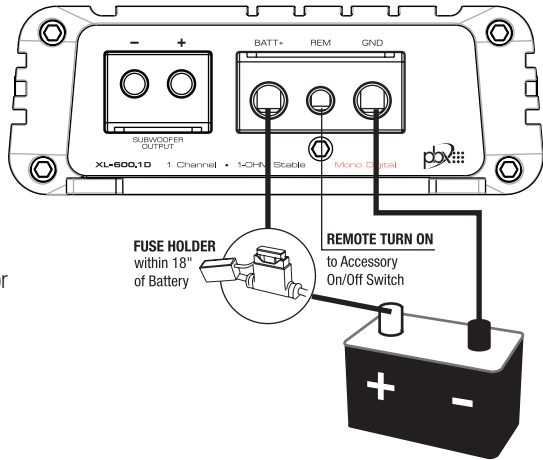

Fig.5 Proper Ground Connection For UTVs, Motorcycles or Boats

REM (Remote Trigger)

This terminal must be connected to a switched +12V source. Typically, remote turn-on leads are provided at the source unit that will turn on and off the amplifier in correspondence with the source. If the source unit does not have a remote turn-on lead, then a power antenna wire can be used. If neither of these leads is available at the source unit, then a switched +12V supply must be used, like the ACC, +12V.

Run a minimum of 18 gauge wire from the amplifier location to the source of the switched +12V lead. If possible, route this wire on the same side of the vehicle as your power cable. Connect the source remote output to the wire. Go back to the amplifier and cut the wire to length. Loosen the screw terminal marked REM on the amplifier. Insert the stripped (bare) portion of the wire into the terminal and tighten the screw securely.

FUSE REQUIREMENTS

Due to the small size of the PowerBass XL series amplifiers, no fuses are incorporated into the panels that normally protect the unit from excessive current. Instead we have included an in-line fuse holder and fuse for this purpose.

It is absolutely vital that the main power lead to the amplifier(s) in the system be separately fused within 18-inches (45cm) of the connection to the battery. The value of this additional fuse (or circuit breaker) should be no greater than the sum of the fuses found on all the equipment being connected to that power wire.

RCA INTERCONNECT WIRING

Traditional radio setup

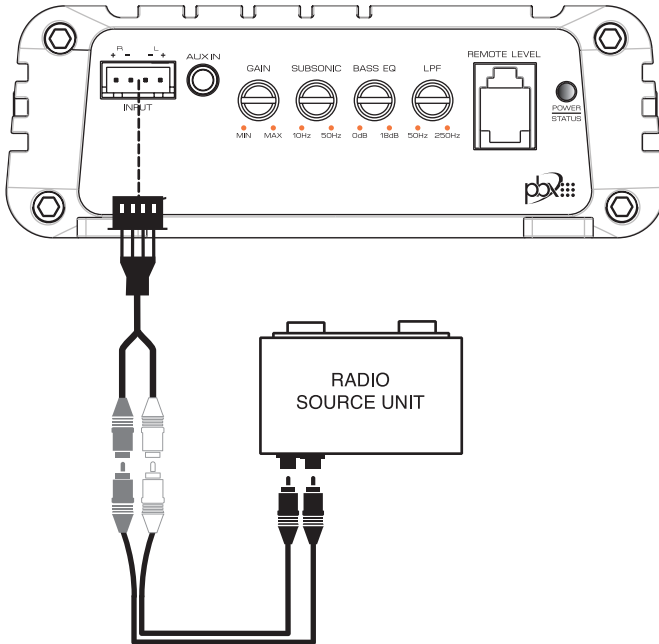

Fig.6 Low Level Input using RCA

Choose the correct length and style of RCA interconnects for your needs. Always use high quality RCA audio cables (not supplied) for signal connections—those with multiple layers of shielding or a twisted pair variety for better noise rejection.

Be extra careful when routing your RCA audio interconnect cables. Car environments are notorious for poorly insulated wires. This means that hiss, engine noise, and fan noise can easily be picked up through RCA cables if run incorrectly.

Make sure that the cables for power and audio signal are not on the same side of the vehicle and that they do not cross each other; this will help reduce any noise that may radiate from the power cable and the signal cable. If an audio cable is too close to a power cable, it may pick up the magnetic field generated by the power cable, which could lead to a loss of quality in your signal.

HIGH LEVEL SPEAKER LEVEL WIRING

Alternate radio setup

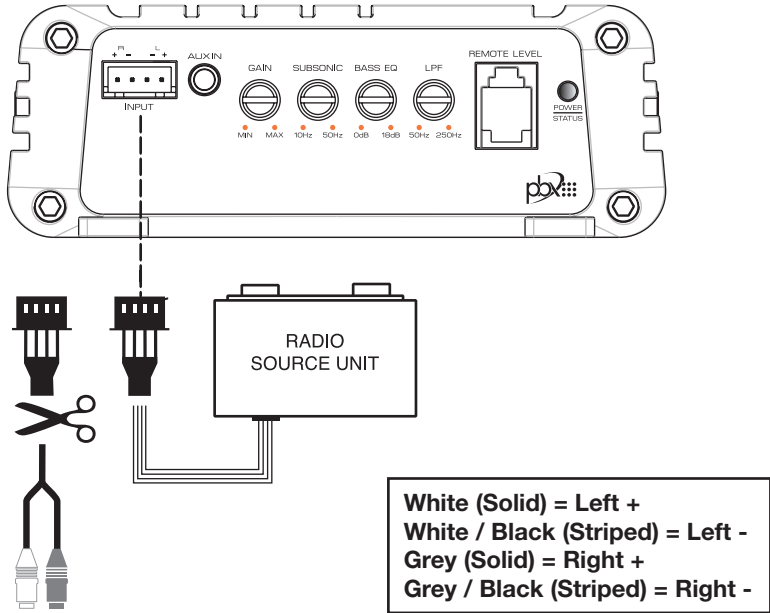
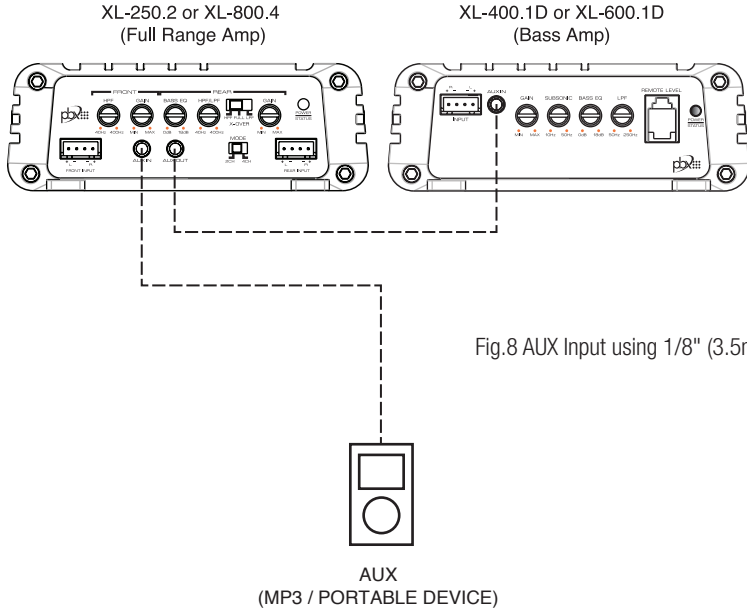

Fig.7 High Level / Speaker Level Input

- 1) Cut RCA Plugs off at the black heatshrink in the middle of the pigtail wires.
- 2) Connect the wires from the speaker output of the radio to the white and grey wires of the amplifier input wires using the color codes in above drawing.

AUX INPUT WIRING

Typical 2 amplifier setup



MP3 or Portable Device as a Source

The XL Powersport Series amplifiers all feature a AUX source input. This allows you to substitute a portable music device such as an iPod, Smartphone, MP3 Player, etc instead of a traditional radio as your music source. Above is a typical two amplifier system—a multi-channel amplifier (our 2-channel XL-250.2 or our 4-channel XL-800.4) to power the full range speakers and a mono bass amplifier (our mono XL-400.1 or XL-600.1D) to power the subwoofer(s).

You will need to use a quality shielded 1/8-inch (3.5mm) stereo male to male audio cable (not supplied) for this type of set up. Route the shielded audio cable using the same care as you would with the RCA interconnect for a traditional source unit.

NOTE: A side panel AUX Input is available for use with portable MP3 players or an iPod ®* Use of this input will override (defeat) the RCA low level inputs.

BLUETOOTH INPUT WIRING

Typical 2 amplifier setup

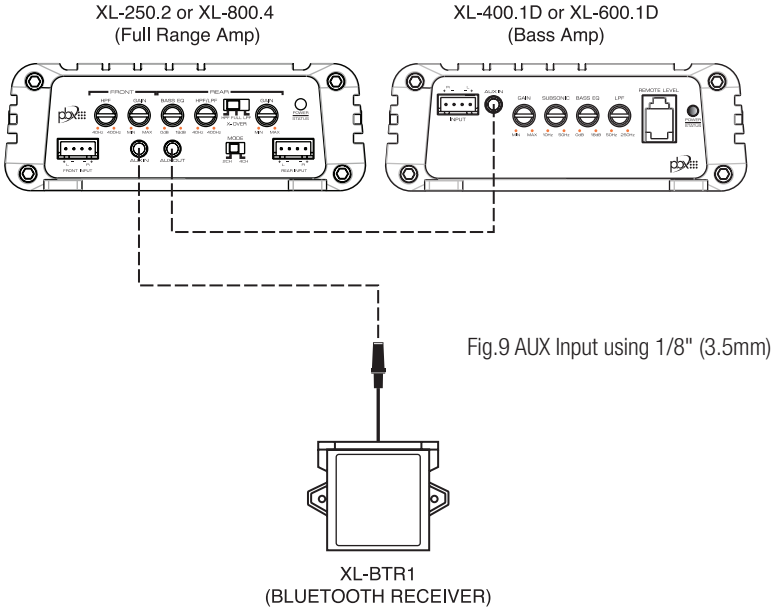

XL-BTR1 as a Source

The XL Powersport Series amplifiers all feature a AUX source input. This allows you to use our XL-BTR1 (pictured) or XL-BTRS, instead of a traditional radio as your music source. Above is a typical two amplifier system—a multi-channel amplifier (our 2-channel XL-250.2 or our 4-4-channel XL-800.4) to power the full range speakers and a mono bass amplifier (our mono XL-400.1 XL-600.1D) to power the subwoofer(s).

You will need to use a quality shielded 1/8-inch (3.5mm) stereo male to male audio cable (not supplied) for this type of set up. Route the shielded audio cable using the same care as you would with the RCA interconnect for a traditional source unit.

NOTE: A side panel AUX Input is available for use with XL-BTR1 or XL-BTRS.* Use of this input will override (defeat) the RCA low level inputs.

SET UP ADJUSTMENTS

Input GAIN Adjustment



Fig.10 GAIN Control

This control allows you to match the input level of the amplifier to the output level of your head unit. Matching the input can be accomplished in four simple steps:

1. Make sure that the remote level control is not plugged in until after the master gain control is set.
2. Set the GAIN control on the amplifier to Min (completely counter clock wise).
3. Turn on the head unit and adjust volume to 2/3 maximum, and set the BASS and TREBLE to zero.
4. Adjust the GAIN control clockwise until the sound just begins to distort, then back off slightly to cut distortion and operate at optimum gain.

Remember, the **GAIN control is not a volume control**. Ignoring these steps above may leave you with damaged speaker and/or a damaged amplifier.

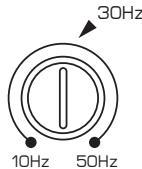

Fig.11 Sub Sonic Adjustment

SUB SONIC Adjustment

The subsonic filter is a 12 dB/octave high-pass filter, with a fully variable cutoff frequency between 10 - 50 Hz. When set at frequencies lower than 30 Hz, it conserves amplifier power without audibly affecting the quality of the sub-bass output.



Fig.12 Low Pass Control

LPF (Low Pass Filter) Adjustment

The crossover frequency adjustment filters out frequencies that you don't want your subwoofer(s) to reproduce. Using the LPF control, adjust the Low Pass Frequency to limit the amount of mid range you want going to your woofer(s). Since musical tastes vary, adjust the crossover by ear while listening to the music of your choice. Be sure to set the tone controls of your source unit to flat before adjusting the crossover.



Fig.13 Bass EQ Control

BASS EQ Control

This special feature is designed to provide you more powerful sound quality, and it allows you to increase the bass output up to +18dB at 45Hz. Keep in mind that more is not always better. Setting the control to the max (18dB) will stress the amplifier and the speakers and could result in damage.

NOTE: More is not always better. By turning the BASS EQ all the way up to +18dB you can over-work the amplifier and send the unit into thermal protection.

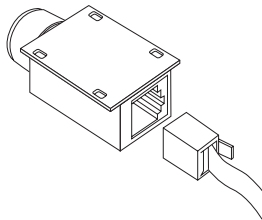

Fig.14 Remote Level Connection

REMOTE LEVEL Controller Connection

Your PowerBass Xtreme Class D amp includes a Remote Level control module. To connect the Remote Level Control to the amplifier, simply insert one end of the 6-pin plug into the REMOTE LEVEL port. Plug the other end into the remote module. Install the module within easy reach on or under your dash.

SPEAKER LOAD

Keep in mind your PowerBass Xtreme Class D amplifier is a High Power Amplifier and not a high current amplifier. In other words it requires a minimum impedance of 2-ohms (1-ohm for the XL-600.1D). If you are unsure of calculating impedance loads please consult your PowerBass Xtreme dealer before damaging your amplifier.

Too low of an impedance could send the amplifier into protection mode and/or permanently damage the amplifier.

XL-400.1D SPEAKER OUTPUT CONFIGURATIONS

2-OHM STABLE DESIGN - MINIMUM IMPEDANCE LOAD IS 2-OHMS

1. A SINGLE VOICE COIL SUBWOOFER SPEAKER

Fig.15 A Single Voice Coil Subwoofer (2-4 ohm)

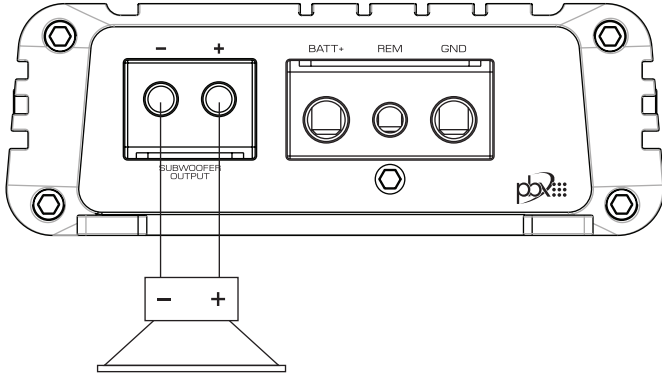

2. TWO SINGLE VOICE COIL SUBWOOFER SPEAKERS

Fig.16 Two 4 ohm Subwoofers with Single Voice Coil (2 ohm)

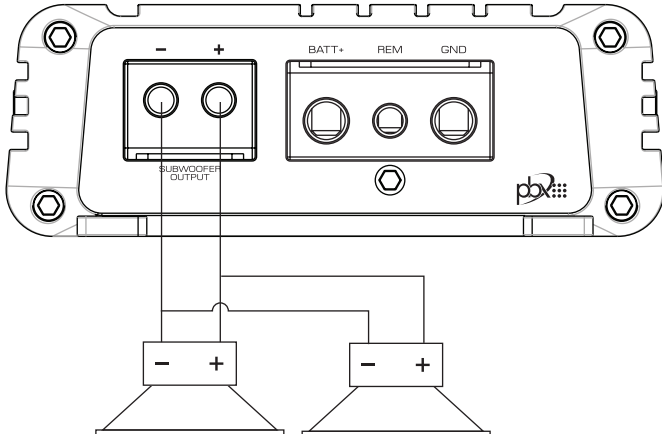

3. ONE DUAL VOICE COIL SUBWOOFER SPEAKER

Fig.17 One Subwoofer (1-4 ohms) with Dual Voice Coil Series Wiring

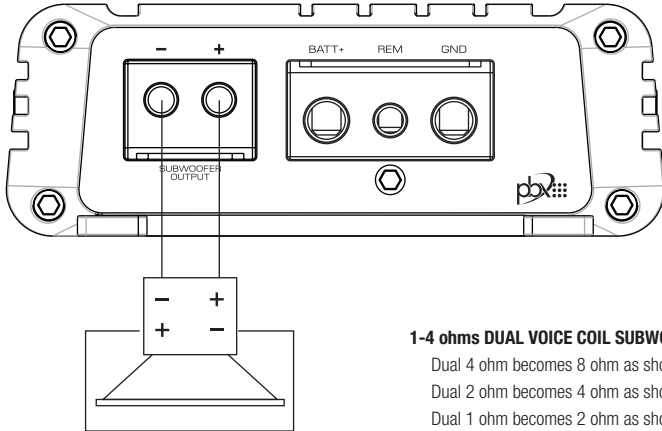

XL-400.1D 2-OHM STABLE DESIGN - Minimum Impedance Load is 2-Ohms

Maintaining proper impedance is critical when wiring the Class D model amplifiers. Improper wiring can cause severe damage to BOTH the woofer and the amplifier. Detailed wiring diagrams are supplied with all PowerBass woofers. IF YOU ARE NOT EXPERIENCED OR UNCOMFORTABLE READING THE WIRING DIAGRAMS CONSULT YOUR AUTHORIZED POWERBASS DEALER BEFORE YOU ATTEMPT TO WIRE THE SYSTEM.

For additional wiring information visit our website www.powerbassusa.com

 **Tech Support**
8:30am-5:30pm Pacific Time
(909) 923-3868
www.powerbassusa.com

XL-600.1D SPEAKER OUTPUT CONFIGURATIONS

1-OHM STABLE DESIGN - MINIMUM IMPEDANCE LOAD IS 1-OHM

3. ONE DUAL VOICE COIL SUBWOOFER SPEAKER

Fig.18 A Single Voice Coil Subwoofer (1~4 ohm)

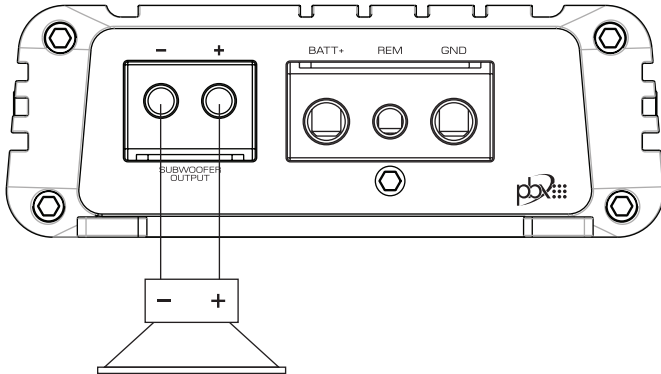

2. TWO SINGLE VOICE COIL SUBWOOFER SPEAKERS

Fig.19 Two 2 ohm Subwoofers with Single Voice Coil (1 ohm)

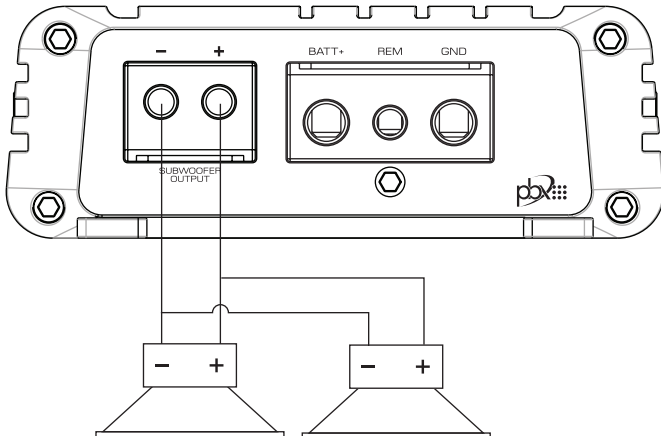

3. ONE DUAL VOICE COIL SUBWOOFER SPEAKER

Fig.20 One Dual Voice Coil Subwoofer Parallel Wiring

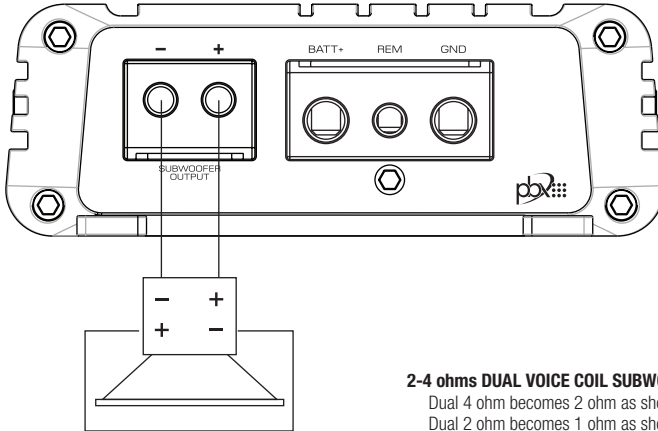

XL-600.1D 1-OHM STABLE DESIGN - Minimum Impedance Load is 1-Ohm

Maintaining proper impedance is critical when wiring the Class D model amplifiers. Improper wiring can cause severe damage to BOTH the woofer and the amplifier. Detailed wiring diagrams are supplied with all PowerBass woofers. IF YOU ARE NOT EXPERIENCED OR UNCOMFORTABLE READING THE WIRING DIAGRAMS CONSULT YOUR AUTHORIZED POWERBASS DEALER BEFORE YOU ATTEMPT TO WIRE THE SYSTEM.

For additional wiring information visit our website www.powerbassusa.com

 **Tech Support**
8:30am-5:30pm Pacific Time
(909) 923-3868
www.powerbassusa.com

RECOMMENDED WIRE SIZES

| Power Cable Selection Chart | | | | | | | |
|------------------------------------|-----------------------------|--------------|---------------|----------------|-----------------|-----------------|-----------------|
| Fuse Total | 4Ft | 4-7Ft | 7-10Ft | 10-13Ft | 13-16 Ft | 16-19 Ft | 19-22 Ft |
| In Amperes | Length of Wire/Gauge | | | | | | |
| 150A - 200A | 2 GA | 2 GA | 2 GA | *1/0* | *1/0* | *1/0* | *1/0* |
| 125A - 150A | 4 GA | 4 GA | 4 GA | 4 GA | 2 GA | 2 GA | 2 GA |
| 105A - 125A | 8 GA | 8 GA | 8 GA | 4 GA | 4 GA | 4 GA | 2 GA |
| 85A - 105A | 8 GA | 8 GA | 8 GA | 4 GA | 4 GA | 4 GA | 4 GA |
| 65A - 85A | 10 GA | 8 GA | 8 GA | 8 GA | 4 GA | 4 GA | 4 GA |
| 50A - 65A | 10 GA | 10 GA | 8 GA | 8 GA | 8 GA | 8 GA | 8 GA |

PowerBass makes several types of amplifier wiring kits to assist with your installation. Consult your local PowerBass dealer for details. For more information about recommended power wire check out our website at www.powerbassusa.com.

PERSONAL NOTES:

Name: _____

Date Purchased: _____

Dealer: _____

Installed By: _____

Model: _____

Serial Number: _____

Miscellaneous: _____

This manual is the exclusive property of PowerBass USA, Inc. Any reproduction of this manual, or use other than its intentions is strictly prohibited without the express consent of PowerBass USA, Inc. © Copyright 2021 PowerBass USA, Inc.

TROUBLESHOOTING TIPS

| Problem | Solution |
|--|--|
| Power LED not ON | <p>With a Volt Ohm Meter (VOM) check:</p> <ul style="list-style-type: none"> • +12 Volt power terminal (should read +12 to +16VDC) • Remote turn-on terminal (should read +12 to +16VDC) • Ground Terminal |
| Power LED lights BLUE, no output | <ul style="list-style-type: none"> • Check RCA connections • Test speaker outputs with known good speaker • Substitute known good Source Unit • Check for signal on the RCA cable with VOM in AC position |
| Power LED lights BLUE, but volume reduces automatically. | <ul style="list-style-type: none"> • Advanced Protection Circuitry is engaging due to high internal temperature of the amplifier. Amplifier requires more air flow around the chassis. If this continues choose a better ventilated mounting location. • High operating temperature can be caused by incorrect input sensitivity level. Readjust the GAIN control. |
| <p>Red Status Protection LED is ON, no output and</p> <ol style="list-style-type: none"> 1. Amp is VERY HOT 2. Amp shuts down ONLY when the vehicle is running 3. No output | <ul style="list-style-type: none"> • Thermal protection is engaged. Check for proper impedance at speaker terminals. Also check for adequate air flow around the amplifier. • Voltage protection engaged. Voltage to the amp is not within the 9-16 VDC operating range. Have the battery/charging system inspected. • Possible short circuit. Check speaker wiring. Must completely turn off amplifier and restart to resume play. |
| Alternator noise (varies with RPM) | <ul style="list-style-type: none"> • Check for damaged RCA cable. • Check routing of RCA cable • Check Source Unit for good ground • Check amp gain setting, turn down if set too high |
| Poor Bass Response | <ul style="list-style-type: none"> • Check speaker polarity, reverse the connection of one speaker only. |

NOTE: After using all the troubleshooting tips above, if the Status L.E.D. is activated and glows RED with no speakers connected to the amplifier, and all the power connections are correct, this would indicate an internal problem with the amplifier. Contact PowerBass USA or your local dealer.

SPECIFICATIONS FOR XL CLASS D MONO AMPLIFIERS

| POWERBASS XTREME CLASS D MODEL | XL-400.1D | XL-600.1D |
|---------------------------------------|------------------|------------------|
| Power Output @ 14.4 VDC Input | | |
| 1 Ohms RMS at THD <0.4% | n/a | 600 x 1 |
| 2 Ohms RMS at THD <0.4% | 400 x 1 | 400 x 1 |
| 4 Ohms RMS at THD <0.4% | 220 x 1 | 200 x 1 |
| Peak Music Power | 800 watts | 1200 watts |
| Signal to Noise Ratio (EIA Rated) | > 85dB | > 85dB |
| Frequency Response | 10Hz - 300Hz | 10Hz - 300Hz |
| CROSSOVER | | |
| Low Pass Filter | 50Hz - 250Hz | 50Hz - 250Hz |
| Crossover Slope | 24dB | 24dB |
| Sub Sonic Filter | 10Hz - 50Hz | 10Hz - 50Hz |
| Variable Bass EQ | 0 - 18dB | 0 - 18dB |
| Input Gain Control | 250mV - 10V | 250mV - 10V |
| Recommended Fuse* | 40A* ATC | 60A* ATC |
| DIMENSIONS | | |
| Width (W) x | 4.5" (115mm) | 4.5" (115mm) |
| Height (H) x | 1.6" (41mm) | 1.6" (41mm) |
| Length (L) mm | 7.5" (191mm) | 8.4" (214mm) |

***REQUIRES EXTERNAL FUSE !**

Important Notes:

- **Due to continuing improvements these specifications are subject to change without any notice.**
- **Do not attempt to fix or repair this unit. Unauthorized repairs will void the manufacturer's warranty.**

POWERBASS ELECTRONICS LIMITED WARRANTY POLICY

PowerBass USA, Inc. offers limited warranty on PowerBass products under normal use on the following terms:

PowerBass Xtreme Amplifiers are to be free of defects in material and workmanship for a period of one (1) year.

This warranty applies only to PowerBass products sold to consumers by Authorized PowerBass Dealers in the United States of America. Products purchased by consumers from a PowerBass dealer in another country are covered only by that country's Distributor and not by PowerBass USA.

This warranty covers only the original purchaser of PowerBass product. In order to receive service, the purchaser must provide PowerBass with the receipt stating the consumer name, dealer, product and date of purchase.

Products found to be defective during the warranty period will be repaired or replaced (with a product deemed to be equivalent) at PowerBass's discretion and will not be liable for incidental or consequential damages. PowerBass will not warranty this product under the following situations:

- **Amplifiers received with apparent rust or corrosion**
- **Any evidence of liquid damage or exposure to excessive heat**
- **Attempted repairs or alterations of any nature**
- **Product that has not been installed according to this owners manual**

Any implied warranties including warranties of fitness for use and merchantability are limited in duration to the period of the express warranty set forth above. Some states do not allow limitations on the length of an implied warranty, so this limitation may not apply. No person is authorized to assume for PowerBass any other liability in connection with the sale of this product.

Please call (909) 923-3868 for PowerBass Customer Service. You must obtain an RA# (Return Authorization Number) to return any product to PowerBass. The RA number must be prominently marked on the outside of the shipping carton or the delivery will be refused. Please pack your return carefully; we are not responsible for items damaged in shipping. Return the defective product along with a copy of the original dated retail sales receipt, plus \$12.00 for handling and diagnostic evaluation to:

**PowerBass USA, Inc.,
Attn: Returns (RA# _____)
2133 S. Green Privado, Ontario, CA 91761**

Residents of HI, AK and US territories will be charged for return shipping. All inquires regarding service and warranty should be sent to the above address.

Removed or altered serial numbers will void this warranty



PowerBass Xtreme – A division of PowerBass USA, Inc.

2133 S. Green Privado – Ontario, CA 91761

Tel. (909) 923-3868 – Fax (909) 923-8048

www.powerbassusa.com

©2021