

powerbass®

X T R E M E



XL-844
XL-844D
XL-1044
XL-1044D
XL-1244
XL-1244D

XL Subwoofer Series

Application Guide

powerbass®

X T R E M E

Thank you and Congratulations

Congratulations on your decision to purchase PowerBass Xtreme “XL” series subwoofers. These top-of-the-line speakers are the result of years of extensive engineering and testing, resulting in the finest car audio subwoofers you can purchase today.



At PowerBass USA, Inc. we are confident you will have many years of outstanding enjoyment from your investment. For maximum performance we recommend that you have your new PowerBass Xtreme product installed by an Authorized PowerBass Xtreme Dealer. Doing so will also automatically extend your warranty to a full THREE-YEAR Period.

To learn more about PowerBass Xtreme, please visit us on the World Wide Web at <http://www.powerbassusa.com>

Δ Warning Δ

Continuous exposure to sound pressure levels in excess of 100 dB can cause permanent hearing loss. PowerBass Xtreme Speakers are capable of producing sound pressure levels well over 170 dB. Please observe all local sound ordinances while listening to your PowerBass Xtreme system. PowerBass USA, Inc. accepts no liability for hearing loss, bodily injury, or property damage due to the result of use or misuse of this product.

POWERBASS XTREME XL WOOFER FEATURES

Proprietary 4-layer, Non-pressed Paper, DDC Finish Cone: The premium grade cones on these subwoofers are blend of papers and wood pulps, and coated in DDC to protect the cone and eliminate distortion. This results in an extremely stiff cone that is resistant to environmental elements while remaining exceptionally stable even under the stress of high sound pressure levels.

Large Roll Santoprene Surround: This treated large roll surround is used to ensure long and linear travel throughout the entire excursion range resulting in more bass output and higher SPL.

Composite Basket: Custom tooled Turbine style low resonant cast polycarbonate basket provides a very rigid high strength foundation.

Chrome Push Input Terminals: These high strength compression loaded speaker terminals ensure maximum current and power transfer.

Vented BASV Voice Coil Former: These specially designed resin coated high temperature voice coils insure high power handling and precise linear excursion while maximizing thermal heat dissipation.

Voice Coil: Made with pure EIW wire for high energy and heat transfer. This makes the voice coil highly efficient, and allows you to play louder for longer.

Xtra Large Motor Structure: Thicker magnets for increased SPL and power handling.

Optimally Designed for Both Sealed and Ported Enclosures: for many sonic and installation applications. This gives you a wide range of uses for the XL-Series Woofers.

Santoprene® is a registered trademark of ExxonMobil Chemical Co.

WIRING GUIDELINES

It is highly recommended that you seek an authorized PowerBass dealer to properly setup, wire and install your woofers for maximum performance.

There are multiple ways to wire your woofers depending on your amplifier and system configuration. The use of multiple voice coils offers you more versatility in system configuration. It is important to know the limits of your amplifier to optimize its performance. It is always better to use your subwoofer in a mono / bridged mode if your amplifier has the capabilities. There are basically four different types of wiring configurations: Series, Parallel, Series-Parallel or Parallel-Parallel. It is possible to change the impedance or load by how the speakers are to be wired and by the quantity of woofers used.

DUAL VOICE COIL WIRING

PARALLEL

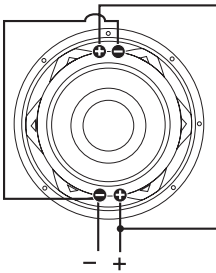

Amplifier

Parallel wiring a dual 4 ohm sub = 2 ohm

SERIES

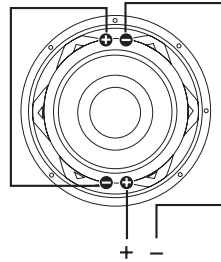

Amplifier

Series wiring a dual 4 ohm sub = 8 ohm

PARALLEL-PARALLEL

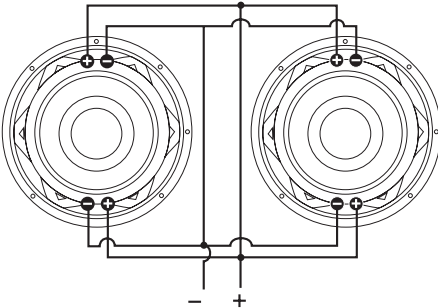

Amplifier

Parallel-Parallel wiring two dual 4 ohm subs = 1 ohm

SERIES PARALLEL

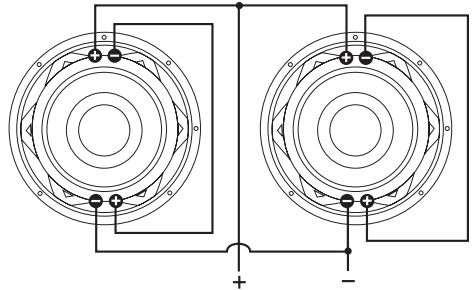

Amplifier

Series-Parallel wiring two dual 4 ohm subs = 4 ohm

NOTE: Never connect only one coil of a Dual Voice Coil (DVC) speaker. BOTH voice coils must be connected to the amplifier

SINGLE VOICE COIL WIRING

STANDARD

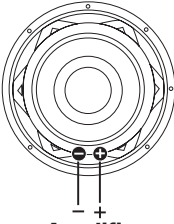

Amplifier

Single 4 ohm woofer

PARALLEL

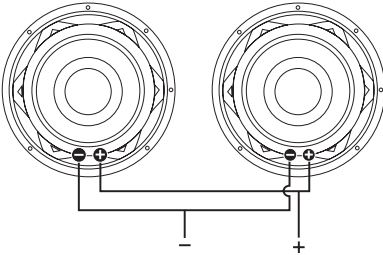

Amplifier

Parallel wiring of two single 4 ohm subs = 2 ohms

PARALLEL

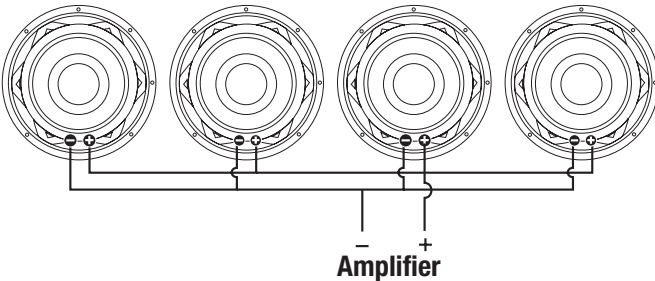

Amplifier

Parallel wiring of four single 4 ohm subs = 1 ohms

SERIES-PARALLEL

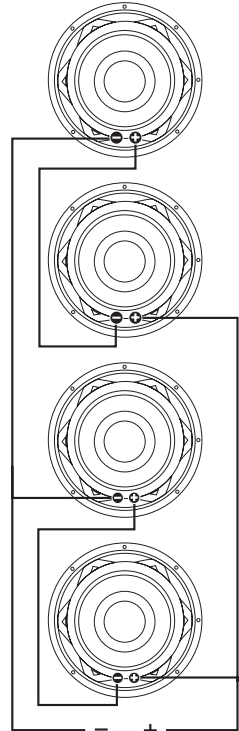

Amplifier

Series/ Parallel wiring of four single

4 ohm subs = 4 ohms

INSTALLATION EXPERIENCE

Installation of PowerBass Xtreme Subwoofers requires experience with a variety of mechanical procedures including enclosure construction. This manual only provides general installation and operation instructions. If you have any reservations about your installation skills, please contact your local Authorized PowerBass dealer for assistance.

CHOOSING A SPEAKER ENCLOSURE

MULTI ENCLOSURE COMPATIBILITY the PowerBass Xtreme Subwoofers are engineered to perform well in various types of enclosures. These subwoofers offer the versatility of being used in either sealed, vented or band-pass enclosures. For maximum performance we recommend you have your new PowerBass Xtreme Subwoofer installed by an Authorized PowerBass Xtreme Dealer.

- **SEALED BOX:** A sealed or acoustic suspension enclosure is easy to build and typically offers a smaller size enclosure and greater power handling. It has the most predictable frequency and phase response; the bass response will roll off slower than that of a ported design. Sealed boxes typically provide the best musical detail and definition. A well-designed sealed enclosure will exhibit smooth frequency response with excellent sound quality and great low bass extension. They also exhibit relatively accurate, punchy bass reproduction for most types of music.

If a sealed enclosure is too large to fit into a specific area of a vehicle, it is possible to decrease the recommended box volume by using 1.5 pounds per cubic feet of low density, high heat specific box stuffing material. PowerBass recommends Fiberglass, Dacron, Poly-Fill or long fiber wool for stuffing the enclosure. ***(Decreasing the box enclosure however should not exceed 20% of the recommended size.)*** When using any type of box stuffing material be sure that the subwoofer's vented pole piece is clear from any obstructions, since covering the pole piece will result in loss of bass and can possibly cause damage to your subwoofer.

The most important aspect of a sealed enclosure is to make sure that it is airtight and solid. If your enclosure has any air leaks or if the panels vibrate or flex, you will experience a loss of bass output. Using glue and some type of sealant (caulk) on all seams will ensure a solid constructed box without any air leaks.

- **VENTED BOX:** Also known as a ported or bass reflex enclosure, this type of box is almost as easy to construct as a sealed enclosure. This design however is more efficient and results in an increase of bass output at certain frequencies. Although vented enclosure has an output advantage at some frequencies, it also has a steeper roll off, which will only affect bass frequencies below port tuning. Air inside the port will move in phase with the subwoofer reinforcing frequencies above the F3 (-3dB point). The SPL advantage of the vented enclosure comes from the fact that the effect of the vent tuning reduces the excursion of the subwoofer near the tuning frequency allowing more SPL to be produced before the subwoofer bottoms.

Damping material should also be used to line the internal walls to reduce any sonic reflection. Because of the characteristics of a vented enclosure, subwoofers typically will become unloaded (act as if it is not in a box) at frequencies of ½ octave below the enclosure tuning frequency. Using a high pass filter / subsonic filter will help prevent the subwoofer from unloading or exceeding its excursion capabilities. It is important to stay within the recommended enclosure designs. ***(PowerBass recommends port placement to coincide on the same panel or baffle that the subwoofer resides on.)***

- **BANDPASS ENCLOSURE:** The most common band-pass enclosure is a combination of a sealed and a vented enclosure working together (4th order or single reflex band-pass system). The rear of the speaker goes into the sealed chamber while the front of the speaker goes into the vented chamber. Because the vent produces all the sound generated from this type of enclosure, sound quality may not be as good as a well-designed ported or sealed design.

Often the sacrifice for sound quality and subwoofer cone control is greater SPL output. However unlike a sealed or vented enclosure, you can effectively increase the enclosure sensitivity with the appropriate tuning choices. You can choose to design a narrow frequency band with very high sensitivity or choose a wide frequency band with the sacrifice of lower sensitivity. The damping effect of the vented chamber reduces the motion of the cone so that potentially higher sound output is achieved without the subwoofer reaching its mechanical limits. Minor deviations from design recommendations however may result in frequency response and distortion problems.

(If you are intending to use multiple subwoofers in your system, PowerBass recommends having separate chambers for each subwoofer if the subwoofers will be operated by two different amplified signals. This will prevent any possible cancellation.)

NOTE: Due to the vented backplate, you must allow an additional 2" behind the subwoofer when designing your speaker enclosure.

ENCLOSURE VOLUME

To calculate the volume required for your enclosure please refer to the Recommended Enclosures section of this guide for your specific model number. These are listed in both cubic feet and liters. One cubic foot is expressed as 12" x 12" x 12" = 1728 cubic inches (see picture below).

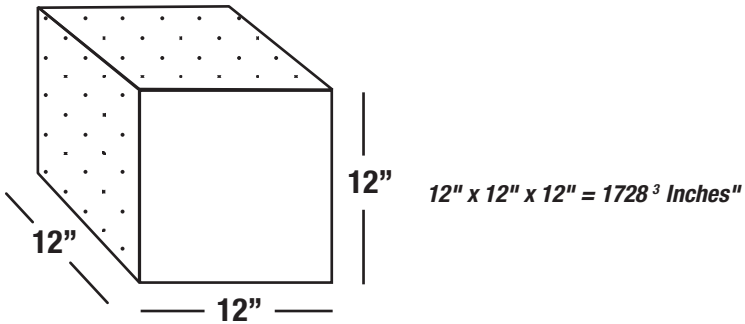

TIPS TO GET THE MOST OUT OF YOUR XL WOOFER

Your PowerBass Xtreme subwoofer has been meticulously engineered and designed to handle high power musical reproduction. Despite their rugged construction, it is possible to damage your speaker if they are improperly used. In general, you will hear distortion as a so-called warning before any damage occurs. If you hear distortion in your system, immediately reduce the musical level to the point where the sound retains its clarity.

1. All PowerBass Xtreme subwoofers require an initial break-in period before it will reach optimum performance. Like any new precision machinery, allow a minimum of several days to one week with normal daily usage to ensure that the suspension has properly been broken-in.
2. Be sure you supply the speakers with enough unclipped amplifier power to drive them properly. (More damage can be done to a speaker by under-powering and clipping your amplifier than any other way!)
3. Where possible, run your Speakers in mono instead of stereo. Most bass is reproduced in mono so there is less chance of any cancellation if played in mono.
4. Where possible, wire your Speakers in parallel instead of series. Bass is reproduced either way but again there is less chance of cancellation in parallel. NOTE: Be sure the amplifier you are using is stable to the resulting impedance of the speaker load!
5. Where possible, a separate amplifier just for your subwoofers should be used with an electronic crossover to set the frequency range.
6. Do not block the front of your speakers or ports. You want as much direct air coupling as possible. Also be sure to round off the inside edges of the port to reduce any port noise.
7. For ported enclosures, keep in mind that you must leave at least twice the port diameter size between the subwoofer and the port itself. Leave at least one time the port diameter between the port and any walls of the enclosure.

Note: The XL woofer basket is constructed of composite materials. Please use the enclosed paper template if you are pre-drilling speaker mounting pilot holes-do not use the woofer as a template.

BOX CONSTRUCTION (SEALED OR VENTED): The material used for enclosure walls should be solid, dense and free of voids or warps. Your enclosure should be made ¾" or 19mm material, Finland or Baltic birch type plywood is recommended where the enclosure will be transported frequently. High-density fiberboard - MDF (not chip board) can be used on permanently installed systems.

Minimum of 1" (25mm) or double ¾" (1-1/2") baffle is recommended on high-powered SPL applications. Corners must be strong and air tight and should not have any air leaks or openings. Joints should be properly filled with glue that will not crack under high stress or impact. If the integrity of the glue seal can't be determined, hot glue or RTV caulking should be used to seal all seams.

Fiber reinforced resin may also be used to form any difficult shapes. However avoid making large panels with resin to eliminate any chances of box flexing, cracking or ratting under high pressure. Bracing made of 2 x 2" or 2 x 4" should be liberally applied either inside or outside the cabinet, depending on whether the cabinet is to be permanently installed or portable. This principle applies to any walls of the enclosure spanning more than 18" long.

Any braces should also be liberally glued or screwed down on edge. Edge-wise drilled, and countersunk holes through the braces can be used for #10-2 Flathead wood screws to avoid the use of more expensive lag bolts. The majority of strength from an enclosure comes from the glue. When using screws be sure to pre-drill holes to avoid splitting the wood.

Note: Do not mount the woofer in the enclosure within 24 hours of sealing the internal joints. The gasses given off as the sealer cures can affect the surround of the speaker resulting in permanent damage that will void the warranty.

WARNING! The use of silicone rubber to seal in a speaker will void the Warranty! If any sealing is needed in addition to the speaker's gasket, use caulking cord or vinyl weather strip.

BREAK IN PERIOD

To get the most from your woofer we recommend a "break-in" period of at **least 40 hours** at no more than 1/3 of maximum volume.

During this time the cone and spider assembly will gradually break in resulting in greater performance and more listening enjoyment.

SUBWOOFER CROSSOVER SETTING

Your PowerBass subwoofers will perform best if they are used in conjunction with a subwoofer crossover of some kind. Using a crossover will remove unwanted high frequencies and allow them to concentrate only on bass. The two most common types of crossovers are "passive" or "active" (electronic crossovers are active). Many amplifiers have a built in Low Pass (LPF) electronic crossover circuit. For optimum subwoofer performance we recommend an initial electronic crossover setting between 80-100Hz and then tuning the bass to your liking.

PARAMETERS FOR POWERBASS XL SERIES WOOFERS

(Due to Constant Improvements, Specifications and Parameters are subject to change without notice)

	XL-844	XL-844D	XL-1044	XL-1044D
VC Impedance (ohms)	4Ω	4Ω + 4Ω	4Ω	4Ω + 4Ω
Test Impedance (ohms)	3.52	1.58	3.24	1.66
Driver Displacement	0.0373	0.0373	0.0831	0.0831
Fs (Hz)	41.9	44.6	29.8	30.5
SD (sqCM)	176.71	176.71	363.05	363.05
Vas (Ltr)	6.44	6.17	36.31	35.99
CMS (μM/N)	146	140	195	193
Mms (g)	98.79	91.18	146.27	140.79
BL™	12.83	7.48	14.48	9.24
Qms	5.532	5.379	4.558	4.225
Qes	0.557	0.721	0.423	0.525
Qts	0.506	0.636	0.387	0.467
No (%)	0.082	0.073	0.219	0.188
Spl (dB)	81.34	81.86	85.60	84.93
Xmax (mm)	5.0 mm	5.0 mm	8.0 mm	9.2 mm
Voice Coil Size (inches)	2.0"	2.0"	2.0"	2.0"
Frequency Response (Hz)	40-400 Hz	43-400Hz	28-350 Hz	29-350Hz
Mounting Depth	4.375"	4.375"	5.25"	5.25"
Power (RMS/Peak)	200/400 watts	200/400 watts	350/700 watts	350/700 watts

PARAMETERS FOR POWERBASS XL SERIES WOOFERS

(Due to Constant Improvements, Specifications and Parameters are subject to change without notice)

	XL-1244	XL-1244D
VC Impedance (ohms)	4Ω	4Ω + 4Ω
Test Impedance (ohms)	3.21	1.56
Driver Displacement	0.121	0.121
Fs (Hz)	27.5	28.2
SD (sqCM)	490.87	490.87
Vas (Ltr)	66.37	55.75
CMS (μM/N)	195	163
Mms (g)	172.16	194.62
BL™	14.38	9.60
Qms	4.794	4.633
Qes	0.462	0.583
Qts	0.421	0.518
No (%)	0.287	0.206
Spl (dB)	86.78	85.35
Xmax (mm)	8.0 mm	9.2 mm
Voice Coil Size (inches)	2.0"	2.0"
Frequency Response (Hz)	26-300 Hz	27-300 Hz
Mounting Depth	5.75"	5.75"
Power (RMS/Peak)	400/800 watts	400/800 watts

RECOMMENDED ENCLOSURES

Please note that these enclosure volume recommendations are for the internal airspace inside the enclosure and include the displacement of the subwoofer and ports. When choosing your enclosure type, please pay close attention to your specific woofer, failing to use the correct enclosure may result in lower power handling and poor sound quality. ***To calculate the internal airspace required, take the internal dimensions of the box. First multiple these number by themselves and then divide this sum by 1728. (W x H x D) / 1728.*** Please contact your authorized PowerBass Xtreme dealer for other designs and specifications. ***(Even though these subwoofers can be used in a ported enclosure, PowerBass recommends a sealed enclosure for optimum performance and sound quality.)***

XL-844 / XL-844D

Optimum Sealed Volume	English Unit	Metric Unit
Gross Vb internal	0.5 Cu.ft	14.2 L
F3 (-3dB Cutoff)	52Hz	52Hz
External Dimensions of the enclosure WXHxD, 3/4" (19mm) MDF	11.5 x 11.5 x 10.25 inch	29.2 x 29.2 x 26 cm
Qtc	0.65	0.65
Pe (Watts-RMS)	50 - 200W	50 - 200W
Acceptable Volumes	0.5 - 1 Cu.ft	14.2 - 28.32L

Optimum Ported Volume	English Unit	Metric Unit
Gross Vb internal	0.75 Cu.ft	21.24 L
External Dimensions of the enclosure WXHxD, 3/4" (19mm) MDF	13.5 x 13.5 x 10.5 inch	34.3 x 34.3 x 26.67 cm
Internal port opening size, W x H	7.5 x 1.5 inch	19.1 x 3.8 cm
Internal port Length	17 inch	43.18 cm
Fb (Box Tuning)	41Hz	41Hz
F3 (-3dB)	47Hz	47Hz
Pe (Watts-RMS)	50 - 200W	50 - 200W
Subsonic Filter Setting If Applicable	40Hz	40Hz

XL-1044 / XL-1044D

Optimum Sealed Volume	English Unit	Metric Unit
Gross Vb internal	0.75 Cu.ft	21.24 L
F3 (-3dB Cutoff)	47Hz	47Hz
External Dimensions of the enclosure WXHxD, 3/4" (19mm) MDF	13.5 x 13.5 x 10.5 inch	34.3 x 34.3 x 26.7 cm
Qtc	0.79	0.79
Pe (Watts-RMS)	100 - 350W	100 - 350W
Acceptable Volumes	0.65 - 1.25 Cu.ft	18.4 - 35.4L

Optimum Ported Volume	English Unit	Metric Unit
Gross Vb internal	1.5 Cu.ft	42.49 L
External Dimensions of the enclosure WXHxD, 3/4" (19mm) MDF	13 x 16 x 17.5 inch	33 x 40.6 x 44.5 cm
Internal port opening size, W x H	10 x 2 inch	25.4 x 50.8 cm
Internal port Length	15.5 inch	39.4 cm
Fb (Box Tuning)	38 Hz	38 Hz
F3 (-3dB)	40 Hz	40 Hz
Pe (Watts-RMS)	100 - 350W	100 - 350W
Subsonic Filter Setting If Applicable	37Hz	37Hz

XL-1244 / XL-1244D

Optimum Sealed Volume	English Unit	Metric Unit
Gross Vb internal	1.25 Cu.ft	35.4 L
F3 (-3dB Cutoff)	44Hz	44Hz
External Dimensions of the enclosure WXHxD, 3/4" (19mm) MDF	15 x 15 x 13.5 inch	38.1 x 38.1 x 34.3 cm
Qtc	0.85	0.85
Pe (Watts-RMS)	100 - 400W	100 - 400W
Acceptable Volumes	1.0 - 2.25 cu.ft	28.32 - 63.7 L

Optimum Ported Volume	English Unit	Metric Unit
Gross Vb internal	2.25 Cu.ft	63.7 L
External Dimensions of the enclosure WXHxD, 3/4" (19mm) MDF	15.5 x 18.5 x 18 inch	39.4 x 47 x 45.7 cm
Internal port opening size, W x H	12.5 x 2.25 inch	31.8 x 57.2 cm
Internal port Length	16 inch	40.6 cm
Fb (Box Tuning)	36Hz	36Hz
F3 (-3dB)	39Hz	39Hz
Pe (Watts-RMS)	100 - 400W	100 - 400W
Subsonic Filter Setting If Applicable	35Hz	35Hz

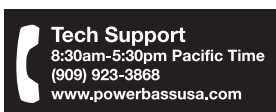

POWERBASS XTREME LIMITED WARRANTY POLICY

PowerBass USA, Inc. offers limited warranty on PowerBass products under normal use on the following terms:

PowerBass Xtreme Speakers are to be free of defects in material and workmanship for a period of one (1) year. The warranty is extended to three (3) years for parts and labor, if an Authorized PowerBass Xtreme Dealer completes the installation.

This warranty applies only to PowerBass products sold to consumers by Authorized PowerBass Dealers in the United States of America. Products purchased by consumers from a PowerBass dealer in another country are covered only by that country's Distributor and not by PowerBass USA.

This warranty covers only the original purchaser of PowerBass product. In order to receive service, the purchaser must provide PowerBass with a valid purchase receipt from an authorized reseller stating the consumer name, dealer, product and date of purchase.

Products found to be defective during the warranty period will be repaired or replaced (with a product deemed to be equivalent) at PowerBass's discretion and will not be liable for incidental or consequential damages. PowerBass will not warranty this product under the following situations:

- **Speakers received with bent frames or water damage**
- **Abuse such as holes in the cone, surround or ripped spider**
- **Voice coil damage due to amplifier clipping or distortion**
- **Product that has not been installed according to this owners manual**

Any implied warranties including warranties of fitness for use and merchantability are limited in duration to the period of the express warranty set forth above. Some states do not allow limitations on the length of an implied warranty, so this limitation may not apply. No person is authorized to assume for PowerBass any other liability in connection with the sale of this product.

Please call (909) 923-3868 for PowerBass Customer Service. You must obtain an RA# (Return Authorization Number) to return any product to PowerBass. **The RA number must be prominently marked on the outside of the shipping carton or the delivery will be refused.** Please pack your return carefully; we are not responsible for items damaged in shipping. Return the defective product along with a copy of the original dated retail sales receipt, plus \$12.00 for handling and diagnostic evaluation to:

**PowerBass USA, Inc.,
Attn: Returns (RA# _____)
2133 S. Green Privado, Ontario, CA 91761**

Residents of HI, AK and US territories will be charged for return shipping. All inquires regarding service and warranty should be sent to the above address.

Removed or altered serial numbers will void this warranty



This manual is the exclusive property of PowerBass USA, Inc. Any reproduction of this manual, or use other than its intentions is strictly prohibited without the express consent of PowerBass USA, Inc. Copyright 2019 PowerBass USA, Inc.



PowerBass Xtreme (PBX) – A division of PowerBass USA, Inc.

2133 S. Green Privado – Ontario, CA 91761

Tel. (909) 923-3868 – Fax (909) 923-8048

www.powerbassusa.com