



PS-DF110T

SINGLE SUBWOOFER DOWNFIRING BASS SYSTEM

Application Guide

Please read through this manual to familiarize yourself with your new speakers. Should your PowerBass Autosound speakers ever require service, you will need to have the original dated receipt.



Thank you and Congratulations

Congratulations on your purchase of Powerbass Autosound speakers. You now own a speaker of uncompromising design and engineering from a factory that truly believes in the relentless pursuit of perfection. Incorporating the highest quality parts and state-of-the-art materials, these speakers display the ultimate balance between high fidelity, performance and long-lasting reliability.



At PowerBass USA, Inc. we are confident you will have many years of outstanding enjoyment from this great SPEAKER investment. For maximum performance we recommend that you have your new PowerBass Autosound product installed by an Authorized PowerBass Autosound Dealer.

To learn more about PowerBass, please visit us on the World Wide Web at
<http://www.powerbassusa.com>

Δ Warning Δ

Continuous exposure to sound pressure levels in excess of 100 dB can cause permanent hearing loss. PowerBass Autosound Speakers are capable of producing sound pressure levels well over 170 dB. Please observe all local sound ordinances while listening to your PowerBass Autosound system. PowerBass USA, Inc. accepts no liability for hearing loss, bodily injury, or property damage due to the result of use or misuse of this product.

POWERBASS AUTOSOUND LOADED ENCLOSURE FEATURES

Air Suspension Bass: Chosen because of its ability to reproduce good low frequency response in a small area, this small footprint sealed enclosure is constructed of 5/8 non-resonant material.

One Piece Injection Molded Cone: This design ensures low distortion bass reproduction and voice coil alignment.

2" Vented KSV Voice Coil Formers: These specially designed resin coated high temperature voice coils ensure high power handling and precise linear excursion while maximizing thermal heat dissipation.

Large Roll Rubber Surrounds: Allows maximum excursion and precision bass reproduction.

Computer Optimized Acoustic Chamber: Engineered for a tight and accurate bass response in space prohibitive applications, such as behind seats or inside compact trunks.

Custom Mounting Brackets: Two brackets each with one side marked Vehicle and the other Cabinet. Use two of the brackets on each enclosure to properly secure the enclosure.

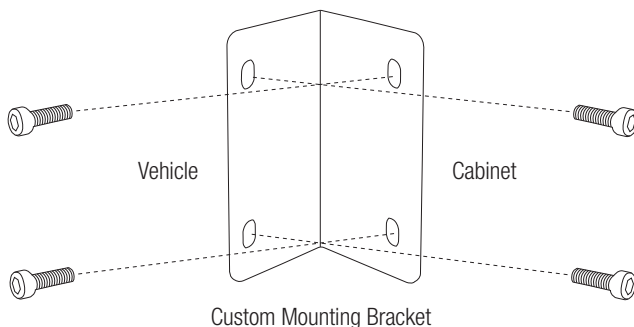

DOWNFIRING SUBWOOFER SYSTEM

(Due to Constant Improvements, Specifications and Parameters are subject to change without notice.)

Model	Size	System Impedance	Frequency Response	Sensitivity 1W/1M	Magnet Size	Voice Coil Dia.	Power RMS/Peak
PS-DF8T	Single 8"	TBA	TBA	TBA	TBA	TBA	TBA
PS-DF110T	Single 10"	4-ohm	38Hz-280Hz	91dB	40 oz.	2.0"	275W/550W

UNPACKING THE ENCLOSURE AIR SUSPENSION

Every attempt has been made to transport your new PowerBass Downfiring Subwoofer system safely. Carefully unpack the enclosure and inspect it thoroughly for any damage that may have occurred during shipping. Notify your local PowerBass dealer immediately should you notice any damage prior to installing the unit. Be sure to keep the carton and packing material until your system is operational. The original boxes will do the best job of protecting your speaker system if they need to be transported.

INSTALLATION EXPERIENCE

Installation of PowerBass Autosound Speakers requires experience with a variety of mechanical and electrical procedures. This manual only provides general installation and operating instructions. If you have any reservations about your installation skills or lack the proper tools, please contact your local PowerBass Autosound dealer for assistance.

ENCLOSURE PLACEMENT RECOMMENDATIONS

Your PowerBass Downfiring Subwoofer system accurately reproduces the lowest portion of the audible frequency range, which is generally considered to be non-directional. As such, the placement within the vehicle is not as critical to achieve good sound reproduction as with full range systems. Typical locations include behind or under the seat in a pick-up truck, crew cab, hatchback and trunks in cars or wherever space is limited.

Use the mounting brackets and hardware supplied to secure the enclosure to the vehicle.

WARNING: Permanent mounting is not only the safest installation, but usually produces the best sound quality. To avoid vehicle damage or personal injury please ensure that the enclosure is securely mounted to a surface with adequate strength and rigidity to support it.

The following placement recommendations and installation tips are the result of many hours of development and experimentation. These examples are provided to you as a guide line. Please feel free to experiment yourself as you may find that other placements can provide you with superior results.

- Make sure all moving parts and factory electrical wires are out of your way and will not interfere after installation.
- Should you choose to install the enclosure with the woofer facing down, make sure there is nothing between the cone and the floor of the vehicle.
- Leave a little slack in the wire to prevent pulling or stretching, this is even more important if the wires will be run under or through the factory interior.
- Use cable ties and wire clamps to prevent the wires from getting caught or shorted.
- We do not recommend placing or installing loaded enclosures where they might be subjected to moisture.
- Correct subwoofer wiring polarity must be observed. The polarity positive side is marked by a (+) sign. Subwoofers wired out of phase will produce little bass.
- Speaker wires should be electrically and physically isolated from the vehicle and routed away from any factory wiring that carries high currents or noise (ie, ABS brake systems and engine computer signals).
- Use speaker wire large enough to carry the full power of your amplifier. 16-gauge or larger should be adequate. (Speaker wire not included)
- Check before drilling any mounting holes

Your PowerBass Downfiring Subwoofer system needs to be installed some place where it can operate efficiently and not endanger the occupants of the vehicle.

The location and orientation of your enclosure will affect the quality and quantity of the bass.

If the enclosure is to be mounted all the way in the back of the vehicle, it works best to point the woofer toward the front of the vehicle. Conversely, if the enclosure is going to be mounted closer to the back seat, pointing the woofer toward the rear of the vehicle will give you the best results.

WIRING AND CONNECTIONS

The PowerBass Downfiring subwoofer system consists of a single 4-ohm voice coil woofer. Check to see that your amplifier is optimized to drive this load.

A single spring loaded push terminal cup provides a quick and easy connection from your bass amplifier to your subwoofer system.

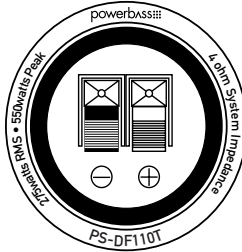

Fig.1

The push terminal input cup is located on the side of the enclosure (Fig 1). For a bare wire connection, strip 1/2 inch (12.7mm) of insulation from each of the two conductors of your speaker wire (not included) to expose bare metal (Fig 2). Carefully twist each of the conductors to eliminate any frayed ends. Push open both terminals, line up the holes, and insert the wires from your amplifier as follows: Positive wire (+) to the Red terminal, Negative wire (-) to the Black terminal. Be careful not to insert the insulated part of the wire into the hole as this will not give you a good connection.

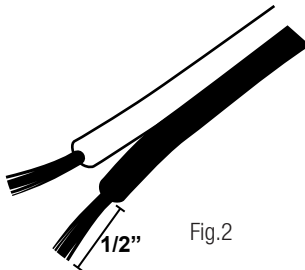

Fig.2

SOUND CHECK

RECOMMENDED POWER

The PS-DF110T is designed to handle up to 275 watts RMS (continuous) and 550 watts maximum (peak) of input power. Therefore an outboard amplifier optimized at 4-ohms will be necessary to drive this system. You will want to use an amplifier powerful enough to provide listening comfort. Generally speaking, an amplifier with the same or slightly higher power rating than the RMS power handling should be selected.

CROSSOVER SETTINGS

The Downfiring woofer enclosure is designed to reproduce low (bass) frequencies only. It does not contain a low pass filter, therefore a crossover network is required for proper operation. If your amplifier includes an electronic (active) crossover, it should be set between 80Hz and 90Hz. Optimum adjustment can be achieved after listening to your favorite music and varying the crossover frequency.

If your amplifier is equipped with a Subsonic Filter it should be set to 25Hz or higher.

BREAK IN PERIOD

To get the most from your woofer we recommend a “break-in” period of **at least 40 hours** (typically 2 weeks) at no more than 1/3 of maximum volume. During this time the cone and spider assembly will gradually break in resulting in greater performance and more listening enjoyment.

CAUTION: Damage to the woofers can occur when an amplifier, regardless of its wattage, is made to play at higher listening levels than its power can clearly produce (usually beyond the “1 to 2 o'clock” position on the volume control). This results in very high levels of audible distortion. Contrary to popular belief, a speaker is more likely to be damaged by trying to get too much volume from a low-powered amp than from a high-powered amp.

NOTE: Lack of bass output is usually caused by the subwoofer being out of phase with reference to the rest of the system. In this case reversing the speaker connection from positive to negative on the terminal cup will correct the problem.

ENCLOSURE DIMENSIONS AND MOUNTING EXAMPLES

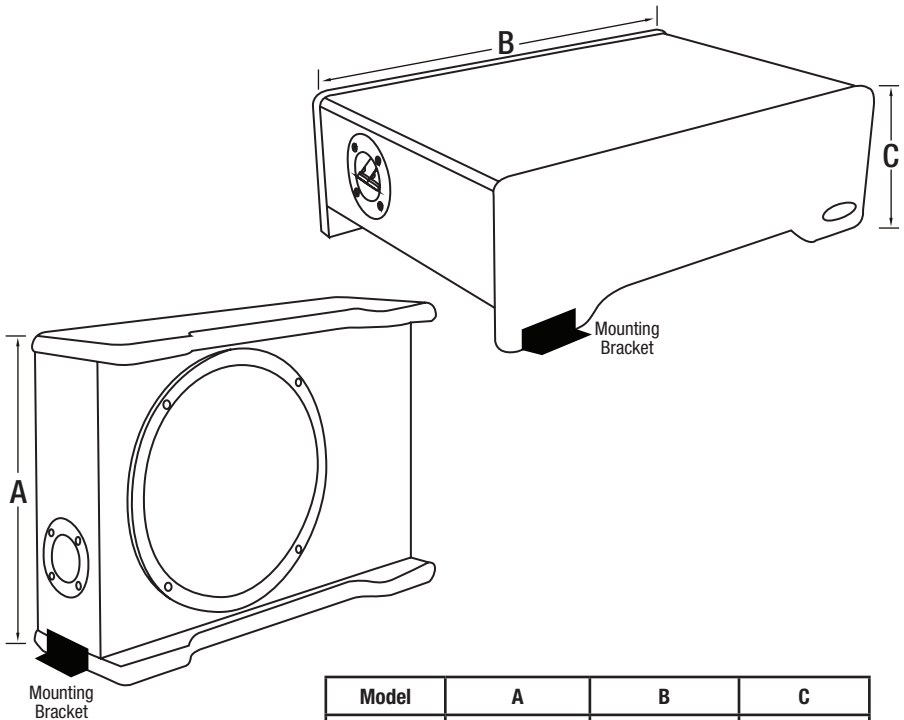

Model	A	B	C
PS-DF8T	TBA	TBA	TBA
PS-DF110T	12.4"/315mm	17.8"/451mm	5.6"/143mm

CARE AND CLEANING

The enclosure is constructed of the same non-resonant material used for premium quality home audio speakers, but covered in a combination of vinyl and carpet instead of veneer. A damp cloth is best to wipe down any dirt on the vinyl surface. Avoid using strong cleaners that may discolor the vinyl wrap. Never apply water or cleaner to the woofer cones.

WARRANTY NOTES

Should a warranty issue arise with our complete subwoofer enclosure PowerBass will replace the defective woofer only. Do not send the entire enclosure, unless the enclosure is defective itself. PowerBass does not warranty the cosmetics of the enclosure once installed in the vehicle.



Product Disposal – Certain international, national and/or local laws and/or regulations may apply regarding the disposal of this product. For further detailed information, please contact the retailer where you purchased this product or the PowerBass Importer/Distributor in your country.

WE WANT YOU LISTENING FOR A LIFETIME

Dear Customer,

Selecting fine audio equipment such as the speakers you've just purchased is only the start of your musical enjoyment. Now it's time to consider how you can maximize the fun and excitement your equipment offers. PowerBass and the Consumer Electronics Association (CEA) want you to get the most out of your equipment by playing at a safe level. One that lets the sound come through loud and clear without annoying, blaring or distortion – and, most importantly, without affecting your sensitive hearing.

Sound can be deceiving. Over time your hearing “comfort level” adapts to higher volumes of sound. So what sounds “normal” can actually be loud and harmful to your hearing. Guard against this by setting your equipment at a safe level BEFORE your hearing adapts.

PowerBass and the CEA want you listening for a lifetime!



This manual is the exclusive property of PowerBass USA, Inc. Any reproduction of this manual, or use other than its intentions is strictly prohibited without the express consent of PowerBass USA, Inc. Copyright 2015 PowerBass USA, Inc.

POWERBASS AUTOSOUND LIMITED WARRANTY POLICY

PowerBass USA, Inc. offers limited warranty on PowerBass products under normal use on the following terms:

PowerBass Autosound Speakers are to be free of defects in material and workmanship for a period of one (1) year.

This warranty applies only to PowerBass products sold to consumers by Authorized PowerBass Dealers in the United States of America. Products purchased by consumers from a PowerBass dealer in another country are covered only by that country's Distributor and not by PowerBass USA.

This warranty covers only the original purchaser of PowerBass product. In order to receive service, the purchaser must provide PowerBass with a valid purchase receipt from an authorized reseller stating the consumer name, dealer, product and date of purchase.

Products found to be defective during the warranty period will be repaired or replaced (with a product deemed to be equivalent) at PowerBass's discretion and will not be liable for incidental or consequential damages. PowerBass will not warranty this product under the following situations:

- **Speakers received with bent frames or water damage**
- **Abuse such as holes in the cone, surround or ripped spider**
- **Voice coil damage due to amplifier clipping or distortion**
- **Product that has not been installed according to this owners manual**

Any implied warranties including warranties of fitness for use and merchantability are limited in duration to the period of the express warranty set forth above. Some states do not allow limitations on the length of an implied warranty, so this limitation may not apply. No person is authorized to assume for PowerBass any other liability in connection with the sale of this product.

Please call (909) 923-3868 for PowerBass Customer Service. You must obtain an RA# (Return Authorization Number) to return any product to PowerBass. **The RA number must be prominently marked on the outside of the shipping carton or the delivery will be refused.** Please pack your return carefully; we are not responsible for items damaged in shipping. Return the defective product along with a copy of the original dated retail sales receipt, plus \$12.00 for handling and diagnostic evaluation to:

**PowerBass USA, Inc.,
Attn: Returns (RA# _____)
2133 S. Green Privado, Ontario, CA 91761**

Residents of HI, AK and US territories will be charged for return shipping. All inquires regarding service and warranty should be sent to the above address.

Removed or altered serial numbers will void this warranty



PowerBass Autosound – A division of PowerBass USA, Inc.
2133 S. Green Privado – Ontario, CA 91761
Tel. (909) 923-3868 – Fax (909) 923-8048
www.powerbassusa.com