

powerbass[®]

X T R E M E



XL-1040T
XL-1040TD
XL-1240T
XL-1240TD

XL SHALLOW SUBWOOFER SERIES

Application Guide

powerbass®

X T R E M E

Thank you and Congratulations

Congratulations on your decision to purchase PowerBass Xtreme "XL" series shallow subwoofers. These top-of-the-line speakers are the result of years of extensive engineering and testing, resulting in the finest car audio subwoofers you can purchase today.



At PowerBass USA, Inc. we are confident you will have many years of outstanding enjoyment from your investment. For maximum performance we recommend that you have your new PowerBass Xtreme product installed by an Authorized PowerBass Xtreme Dealer. Doing so will also automatically extend your warranty to a full THREE-YEAR Period.

To learn more about PowerBass Xtreme, please visit us on the World Wide Web at
<http://www.powerbassusa.com>

Δ Warning Δ

Continuous exposure to sound pressure levels in excess of 100 dB can cause permanent hearing loss. PowerBass Xtreme Speakers are capable of producing sound pressure levels well over 170 dB. Please observe all local sound ordinances while listening to your PowerBass Xtreme system. PowerBass USA, Inc. accepts no liability for hearing loss, bodily injury, or property damage due to the result of use or misuse of this product.

POWERBASS XL SHALLOW WOOFER FEATURES

Flat Injection Molded Cone Ridges strengthen the poly cone to withstand punishment while ensuring low distortion in a small enclosure.

Large Roll Santoprene Surround This large roll surround allows maximum excursion and precision bass reproduction.

Composite Basket: Custom tooled Turbine style low resonant cast polycarbonate basket provides a very rigid high strength foundation.

Chrome Push Input Terminals: These high strength compression loaded speaker terminals ensure maximum current and power transfer.

2" KSV Voice Coil Former These specially designed resin coated high temperature voice coils ensure high power handling and precise liner excursion while maximizing thermal heat dissipation by forcing air through the coil wire out to the vents on the basket sides.

Optimally Designed for Small Sealed Enclosures Engineered to get the most bass in a small place.

Santoprene® is a registered trademark of ExxonMobil Chemical Co.

WIRING GUIDELINES

It is highly recommended that you seek an authorized PowerBass dealer to properly setup, wire and install your woofers for maximum performance.

There are multiple ways to wire your woofers depending on your amplifier and system configuration. It is important to know the limits of your amplifier to optimize its performance. It is always better to use your subwoofer in a mono/bridged mode if your amplifier has the capabilities. There are basically four different types of wiring configurations: Series, Parallel, Series-Parallel or Parallel-Parallel. It is possible to change the impedance or load by how the speakers are to be wired and by the quantity of woofers used.

DUAL VOICE COIL WIRING

PARALLEL

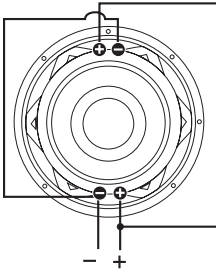

Amplifier

Parallel wiring a dual 4 ohm sub = 2 ohm

SERIES

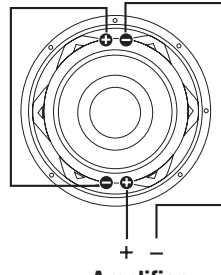

Amplifier

Series wiring a dual 4 ohm sub = 8 ohm

PARALLEL-PARALLEL

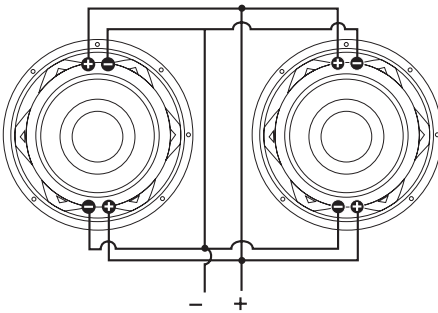

Amplifier

Parallel-Parallel wiring two dual 4 ohm subs = 1 ohm

SERIES PARALLEL

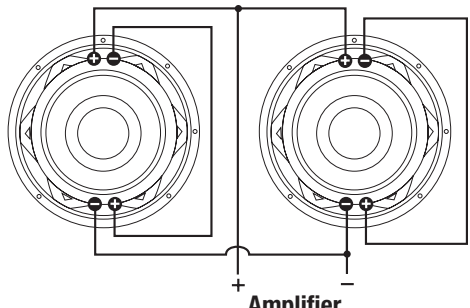

Amplifier

Series-Parallel wiring two dual 4 ohm subs = 4 ohm

NOTE: Never connect only one coil of a Dual Voice Coil (DVC) speaker. BOTH voice coils must be connected to the amplifier

SINGLE VOICE COIL WIRING Continued

STANDARD

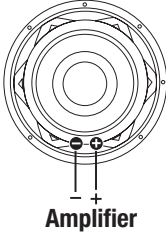

Single 4 ohm woofer

PARALLEL

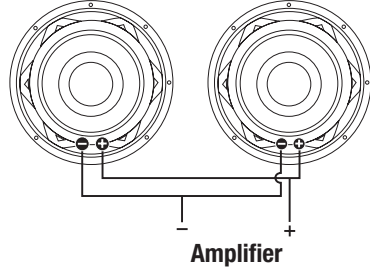

Parallel wiring of two single 4 ohm subs = 2 ohms

SERIES-PARALLEL

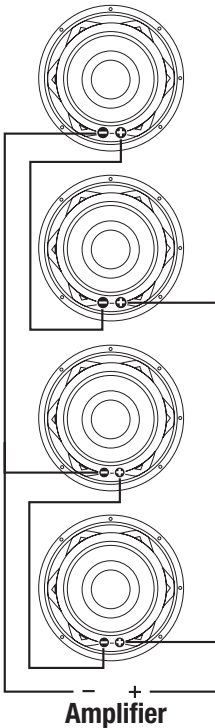

Series/ Parallel wiring of four single
4 ohm subs = 4 ohms

PARALLEL

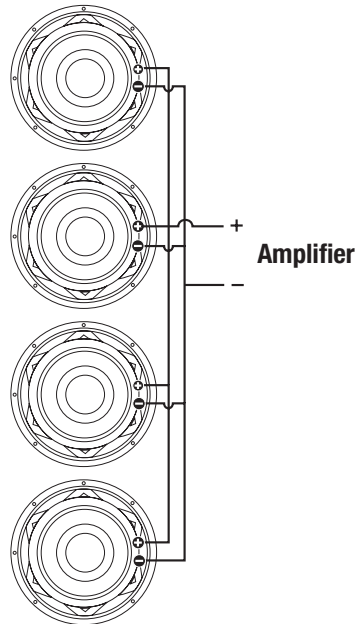

Parallel wiring of four single 4 ohm subs = 1 ohms

INSTALLATION EXPERIENCE

Installation of PowerBass Xtreme Subwoofers requires experience with a variety of mechanical procedures including enclosure construction. This manual only provides general installation and operation instructions. If you have any reservations about your installation skills, please contact your local Authorized PowerBass dealer for assistance.

CHOOSING A SPEAKER ENCLOSURE

ENCLOSURE COMPATIBILITY: The PowerBass XL Shallow subwoofers are engineered specifically to perform their best in small sealed enclosures. For maximum performance we recommend you have your new PowerBass Xtreme subwoofer installed by an Authorized PowerBass Xtreme Dealer.

- **SEALED BOX:** A sealed or acoustic suspension enclosure is easy to build and typically offers a smaller size enclosure and greater power handling. It has the most predictable frequency and phase response; the bass response will roll off slower than that of a ported design. Sealed boxes typically provide the best musical detail and definition. A well-designed sealed enclosure will exhibit smooth frequency response with excellent sound quality and great low bass extension. They also exhibit relatively accurate, punchy bass reproduction for most types of music. If a sealed enclosure is too large to fit into a specific area of a vehicle, it is possible to decrease the recommended box volume by using 1.5 pounds per cubic feet of low density, high heat specific box stuffing material. PowerBass recommends Fiberglass, Dacron, Poly-Fill or long fiber wool for stuffing the enclosure. ***(Decreasing the box enclosure however should not exceed 20% of the recommended size.)***

When using any type of box stuffing material be sure that the subwoofer's vented pole piece is clear from any obstructions, since covering the pole piece will result in loss of bass and can possibly cause damage to your subwoofer. The most important aspect of a sealed enclosure is to make sure that it is airtight and solid. If your enclosure has any air leaks or if the panels vibrate or flex, you will experience a loss of bass output. Using glue and some type of sealant (caulk) on all seams will ensure a solid constructed box without any air leaks.

- **VENTED BOX:** Not recommended
- **BANDPASS ENCLOSURE:** Not recommended

(If you are intending to use multiple subwoofers in your system, PowerBass recommends having separate chambers for each subwoofer if the subwoofers will be operated by two different amplified signals. This will prevent any possible cancellation.)

ENCLOSURE VOLUME

To calculate the volume required for your enclosure please refer to the Recommended Enclosures section of this guide for your specific model number. These are listed in both cubic feet and liters. One cubic foot is expressed as $12'' \times 12'' \times 12'' = 1728$ cubic inches (see picture below).

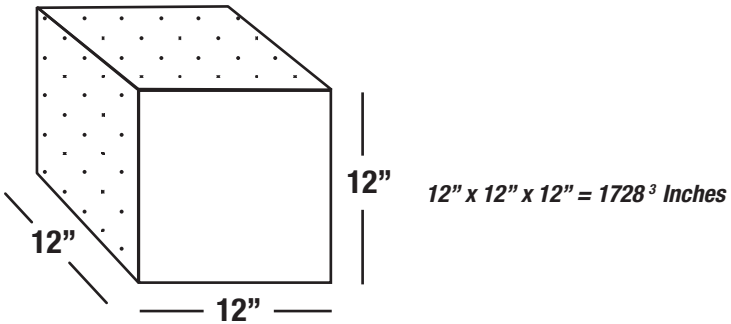

TIPS TO GET THE MOST OUT OF YOUR XL WOOFER

Your PowerBass Xtreme subwoofer has been meticulously engineered and designed to handle high power musical reproduction. Despite their rugged construction, it is possible to damage your speaker if they are improperly used. In general, you will hear distortion as a so-called warning before any damage occurs. If you hear distortion in your system, immediately reduce the musical level to the point where the sound retains its clarity.

1. All PowerBass Xtreme subwoofers require an initial break-in period before it will reach optimum performance. Like any new precision machinery, allow a minimum of several days to one week with normal daily usage to ensure that the suspension has properly been broken-in.
2. Be sure you supply the speakers with enough unclipped amplifier power to drive them properly. (More damage can be done to a speaker by under-powering and clipping your amplifier than any other way!)
3. Where possible, run your Speakers in mono instead of stereo. Most bass is reproduced in mono so there is less chance of any cancellation if played in mono.
4. Where possible, wire your Speakers in parallel instead of series. Bass is reproduced either way but again there is less chance of cancellation in parallel. NOTE: Be sure the amplifier you are using is stable to the resulting impedance of the speaker load!
5. Where possible, a separate amplifier just for your subwoofers should be used with an electronic crossover to set the frequency range.
6. Do not block the front of your speakers or ports. You want as much direct air coupling as possible. Also be sure to round off the inside edges of the port to reduce any port noise.
7. For ported enclosures, keep in mind that you must leave at least twice the port diameter size between the subwoofer and the port itself. Leave at least one time the port diameter between the port and any walls of the enclosure.

Note: The XL woofer basket is constructed of composite materials. Please use the enclosed paper template if you are pre-drilling speaker mounting pilot holes-do not use the woofer as a template.

BOX CONSTRUCTION (SEALED OR VENTED): The material used for enclosure walls should be solid, dense and free of voids or warps. Your enclosure should be made ¾" or 19mm material, Finland or Baltic birch type plywood is recommended where the enclosure will be transported frequently. High-density fiberboard - MDF (not chip board) can be used on permanently installed systems.

Minimum of 1" (25mm) or double ¾" (1-1/2") baffle is recommended on high-powered SPL applications. Corners must be strong and air tight and should not have any air leaks or openings. Joints should be properly filled with glue that will not crack under high stress or impact. If the integrity of the glue seal can't be determined, hot glue or RTV caulking should be used to seal all seams.

Fiber reinforced resin may also be used to form any difficult shapes. However avoid making large panels with resin to eliminate any chances of box flexing, cracking or ratting under high pressure. Bracing made of 2 x 2" or 2 x 4" should be liberally applied either inside or outside the cabinet, depending on whether the cabinet is to be permanently installed or portable. This principle applies to any walls of the enclosure spanning more than 18" long.

Any braces should also be liberally glued or screwed down on edge. Edge-wise drilled, and countersunk holes through the braces can be used for #10-2 Flathead wood screws to avoid the use of more expensive lag bolts. The majority of strength from an enclosure comes from the glue. When using screws be sure to pre-drill holes to avoid splitting the wood.

Note: Do not mount the woofer in the enclosure within 24 hours of sealing the internal joints. The gasses given off as the sealer cures can affect the surround of the speaker resulting in permanent damage that will void the warranty.

WARNING! The use of silicone rubber to seal in a speaker will void the Warranty! If any sealing is needed in addition to the speaker's gasket, use caulking cord or vinyl weather strip.

BREAK IN PERIOD

To get the most from your woofer we recommend a "break-in" period of at **least 40 hours** at no more than 1/3 of maximum volume.

During this time the cone and spider assembly will gradually break in resulting in greater performance and more listening enjoyment.

SUBWOOFER CROSSOVER SETTING

Your PowerBass subwoofers will perform best if they are used in conjunction with a subwoofer crossover of some kind. Using a crossover will remove unwanted high frequencies and allow them to concentrate only on bass. The two most common types of crossovers are "passive" or "active" (electronic crossovers are active). Many amplifiers have a built in Low Pass (LPF) electronic crossover circuit. For optimum subwoofer performance we recommend an initial electronic crossover setting between 80-100Hz and then tuning the bass to your liking.

PREPARING FOR INSTALLATION

NOTE: The tools listed below may be required for basic installation.

- An electric drill with bits
- Saber, circular and jig saw
- Phillips-head and standard screwdrivers
- Wire strippers
- Crimping tool and needle-nose pliers
- Silicone sealant (for enclosures), closed cell weather-stripping (for the speakers)

INSTALLATION PRECAUTIONS

NOTE: Proceed only if you are a qualified installer otherwise; let your dealer do it.

- Always wear protective eyewear when using tools.
- Turn off all stereo and other electrical devices before you begin.
- Disconnect the (–) negative lead from your vehicle's battery.
- Keep the speakers in the package until final installation, and always rest it with the cone facing up. Never use force when installing a speaker.
- Locate all fuel lines, brake lines, oil lines, and electrical cables when planning your installation.
- Check to see if there is enough clearance behind the mounting surface before drilling holes or installing screws for proper speaker ventilation.
- Also make sure there's enough front clearance for speaker cone excursion. Failure to do this could cause the cone to vibrate against any obstructing object.
- Use a utility knife to trim away fabric from the speaker mounting hole location before drilling. It is hard to get a good seal if you have both the carpet & subwoofer gasket between the speaker and the enclosure.
- When running speaker wires through sheet metal, be sure to use grommets to properly insulate the wires from metal edges.

PARAMETERS FOR POWERBASS XL SERIES WOOFERS

(Due to Constant Improvements, Specifications and Parameters are subject to change without notice.)

	XL-1040T	XL-1040TD	XL-1240T	XL-1240TD
VC Impedance (ohms)	4Ω	4Ω + 4Ω	4Ω	4Ω + 4Ω
Test Impedance (ohms)	3.2Ω	6.8Ω	3.2Ω	6.8Ω
Driver Displacement	0.0771 cu ft	0.0771 cu ft	0.126 cu ft	0.0771 cu ft
Fs (Hz)	35	37.492	33	31.783
SD (sqCM)	346.360	346.360	510.70	510.70
Vas (Ltr)	21.02	17.237	42.369	45.481
CMS (μM/N)	127.039	101.301	98.129	122.804
Mms (g)	164.056	177.884	202.087	204.196
BL™	14.693	19.957	15.247	17.568
Qms	3.655	4.693	4.458	4.649
Qes	0.577	0.715	0.597	0.898
Qts	0.487	0.621	0.526	0.753
No (%)	0.147	0.123	0.214	0.157
Spl (dB)	88	82.9	89	84
Xmax One Way (mm)	7.5	7.5	7.5	7.5
Voice Coil Size (inches)	2.0	2.0	2.0	2.0
Frequency Response (Hz)	35-500	35-500	33-450	33-450
Mounting Depth	3.4" (86mm)	3.4" (86mm)	3.8" (97mm)	3.8" (97mm)
Power (RMS/Peak)	350/700 watts	350/700 watts	400/800 watts	400/800 watts

RECOMMENDED ENCLOSURES

Please note that these enclosure volume recommendations are for the internal airspace inside the enclosure and include the displacement of the subwoofer and ports. When choosing your enclosure type, please pay close attention to your specific woofer, failing to use the correct enclosure may result in lower power handling and poor sound quality. ***To calculate the internal airspace required, take the internal dimensions of the box. First multiply these number by themselves and then divide this sum by 1728. (W x H x D) / 1728.*** Please contact your authorized PowerBass Xtreme dealer for other designs and specifications. ***(Even though these subwoofers can be used in a ported enclosure, PowerBass recommends a sealed enclosure for optimum performance and sound quality.)***



XL-1040T / XL-1040TD

Optimum Sealed Volume	English Unit	Metric Unit
Gross Vb internal	0.30 cu ft	8.50 ltr
Fc, (resonance frequency of the closed box system)	56 Hz	56 Hz
F3 (-3dB Cutoff)	50 Hz	50 Hz
Displacement	0.04 cu ft	1.133 L
Qtc	1.01	
Pe (Watts-RMS)	350	350
Acceptable Volumes	0.25 – 0.75 cu ft	7.08 – 21.24 L

XL-1240T / XL-1240TD

Optimum Sealed Volume	English Unit	Metric Unit
Gross Vb internal	0.40 cu ft	11.33 ltr
Fc, (resonance frequency of the closed box system)	52 Hz	52 Hz
F3 (-3dB Cutoff)	48 Hz	48 Hz
External Dimensions of the enclosure WXHXD, 3/4" (19mm) MDF	0.06 cu ft	1.7 cu ft
Qtc	1.03	
Pe (Watts-RMS)	400	400
Acceptable Volumes	0.30 – 0.85 cu ft	8.50 – 24.07 ltr

WE WANT YOU LISTENING FOR A LIFETIME

Dear Customer,

Selecting fine audio equipment such as the speakers you've just purchased is only the start of your musical enjoyment. Now it's time to consider how you can maximize the fun and excitement your equipment offers. PowerBass and the Consumer Electronics Association (CEA) want you to get the most out of your equipment by playing at a safe level. One that lets the sound come through loud and clear without annoying, blaring or distortion – and, most importantly, without affecting your sensitive hearing.

Sound can be deceiving. Over time your hearing “comfort level” adapts to higher volumes of sound. So what sounds “normal” can actually be loud and harmful to your hearing. Guard against this by setting your equipment at a safe level BEFORE your hearing adapts.

PowerBass and the CEA want you listening for a lifetime!



This manual is the exclusive property of PowerBass USA, Inc. Any reproduction of this manual, or use other than its intentions is strictly prohibited without the express consent of PowerBass USA, Inc. Copyright 2017 PowerBass USA, Inc.

POWERBASS XTREME LIMITED WARRANTY POLICY

PowerBass USA, Inc. offers limited warranty on PowerBass products under normal use on the following terms:

PowerBass Xtreme Speakers are to be free of defects in material and workmanship for a period of one (1) year. The warranty is extended to three (3) years for parts and labor, if an Authorized PowerBass Xtreme Dealer completes the installation.

This warranty applies only to PowerBass products sold to consumers by Authorized PowerBass Dealers in the United States of America. Products purchased by consumers from a PowerBass dealer in another country are covered only by that country's Distributor and not by PowerBass USA.

This warranty covers only the original purchaser of PowerBass product. In order to receive service, the purchaser must provide PowerBass with a valid purchase receipt from an authorized reseller stating the consumer name, dealer, product and date of purchase.

Products found to be defective during the warranty period will be repaired or replaced (with a product deemed to be equivalent) at PowerBass's discretion and will not be liable for incidental or consequential damages. PowerBass will not warranty this product under the following situations:

- **Speakers received with bent frames or water damage**
- **Abuse such as holes in the cone, surround or ripped spider**
- **Voice coil damage due to amplifier clipping or distortion**
- **Product that has not been installed according to this owners manual**

Any implied warranties including warranties of fitness for use and merchantability are limited in duration to the period of the express warranty set forth above. Some states do not allow limitations on the length of an implied warranty, so this limitation may not apply. No person is authorized to assume for PowerBass any other liability in connection with the sale of this product.

Please call (909) 923-3868 for PowerBass Customer Service. You must obtain an RA# (Return Authorization Number) to return any product to PowerBass. **The RA number must be prominently marked on the outside of the shipping carton or the delivery will be refused.** Please pack your return carefully; we are not responsible for items damaged in shipping. Return the defective product along with a copy of the original dated retail sales receipt, plus \$12.00 for handling and diagnostic evaluation to:

**PowerBass USA, Inc.,
Attn: Returns (RA# _____)
2133 S. Green Privado, Ontario, CA 91761**

Residents of HI, AK and US territories will be charged for return shipping. All inquires regarding service and warranty should be sent to the above address.

Removed or altered serial numbers will void this warranty



PowerBass Xtreme – A division of PowerBass USA, Inc.

2133 S. Green Privado – Ontario, CA 91761

Tel. (909) 923-3868 – Fax (909) 923-8048

www.powerbassusa.com